

# Avseal<sup>®</sup> XT

ProSet<sup>®</sup> XT, PB2500, PB3400, 7287 and AV<sup>®</sup>5 Tools

©2019 STANLEY Black & Decker

All rights reserved.

The information provided may not be reproduced and/or made public in any way and through any means (electronically or mechanically) without prior explicit and written permission from STANLEY Engineered Fastening. The information provided is based on the data known at the moment of the introduction of this product. STANLEY Engineered Fastening pursues a policy of continuous product improvement and therefore the products may be subject to change. The information provided is applicable to the product as delivered by STANLEY Engineered Fastening. Therefore, STANLEY Engineered Fastening cannot be held liable for any damage resulting from deviations from the original specifications of the product.

The information available has been composed with the utmost care. However, STANLEY Engineered Fastening will not accept any liability with respect to any faults in the information nor for the consequences thereof. STANLEY Engineered Fastening will not accept any liability for damage resulting from activities carried out by third parties. The working names, trade names, registered trademarks, etc. used by STANLEY Engineered Fastening should not be considered as being free, pursuant to the legislation with respect to the protection of trade marks.

**SAFETY RULES**

This technical datasheet must be read with particular attention to the safety rules and operating instructions listed in associated placing tool Instruction Manuals, by any person fitting or operating the Avseal® XT nose assemblies and hand tools.

**INTENT OF USE**

The Avseal® XT nose assemblies in combination with the ProSet® XT, PB2500, PB3400, 7287 and AV®5 tools are designed for placing Stanley Engineered Fastening Avseal® XT blind sealing plugs only. The correct placing tool and nose assembly must be selected for each fastener size as shown in Tables 1a and 1b below.

**IMPORTANT**

**The tools and nose assemblies must be used in accordance with the safety rules and fitting instructions contained within this datasheet and the tool instruction manual.**

**The placing of fasteners not included in this datasheet could have a detrimental impact on the working life of the tool and nose assemblies and could invalidate the warranty.**

The table on page 2 provide a full list of part numbers for the nose tips, nose assemblies and base tools required to place each Avseal® XT size. These tables should be used to select and order the correct placing equipment.

For the fitting and servicing instructions for each nose assembly refer to the page number provided in the tables on pages 4 to 8.

**IMPORTANT**

**Nose assemblies do NOT include nose tips. Nose tips must be ordered separately.**

**Avseal® XT Nose Equipment Part Numbers**

AVSEAL® XT DIAMETER	TOOL	NOSE ASSEMBLY (TOOL FREE TYPE)	NOSE ASSEMBLY (STANDARD TYPE)	NOSE TIP		PAGE REF.
	MODEL			EXTENSION	PART NUMBER	
5.0	XT2	76002-16100	-	2mm	71213-16405	3
	PB2500	71702-16200	-	2mm	71702-16205	9
6.0	XT3 XT4	76003-16100	71210-16100*	2mm	71213-16406	5 & 7
	PB3400	71701-16200	-	2mm	71701-16202	9
7.0	XT3 XT4	76003-16200	71220-16100*	2mm	71223-16001	5 & 7
	PB3400	71701-16300	-	2mm	71702-16302	9
8.0	XT4	76004-16100	71230-16100*	2mm	71233-16001	5 & 7
10.0	7287 AV5	-	07220-06700	2mm	73200-07002	11

\*XT3 Adapter Kit 76003-20400 required to fit nose assembly.

## PROSET XT2 NOSE ASSEMBLIES – 76002-16100

**IMPORTANT**

Read the safety warnings listed in the ProSet® XT1 and ProSet® XT2 Instruction Manual carefully before putting into service.

**IMPORTANT**

The air supply must be turned off or disconnected before fitting or removing the nose assembly.

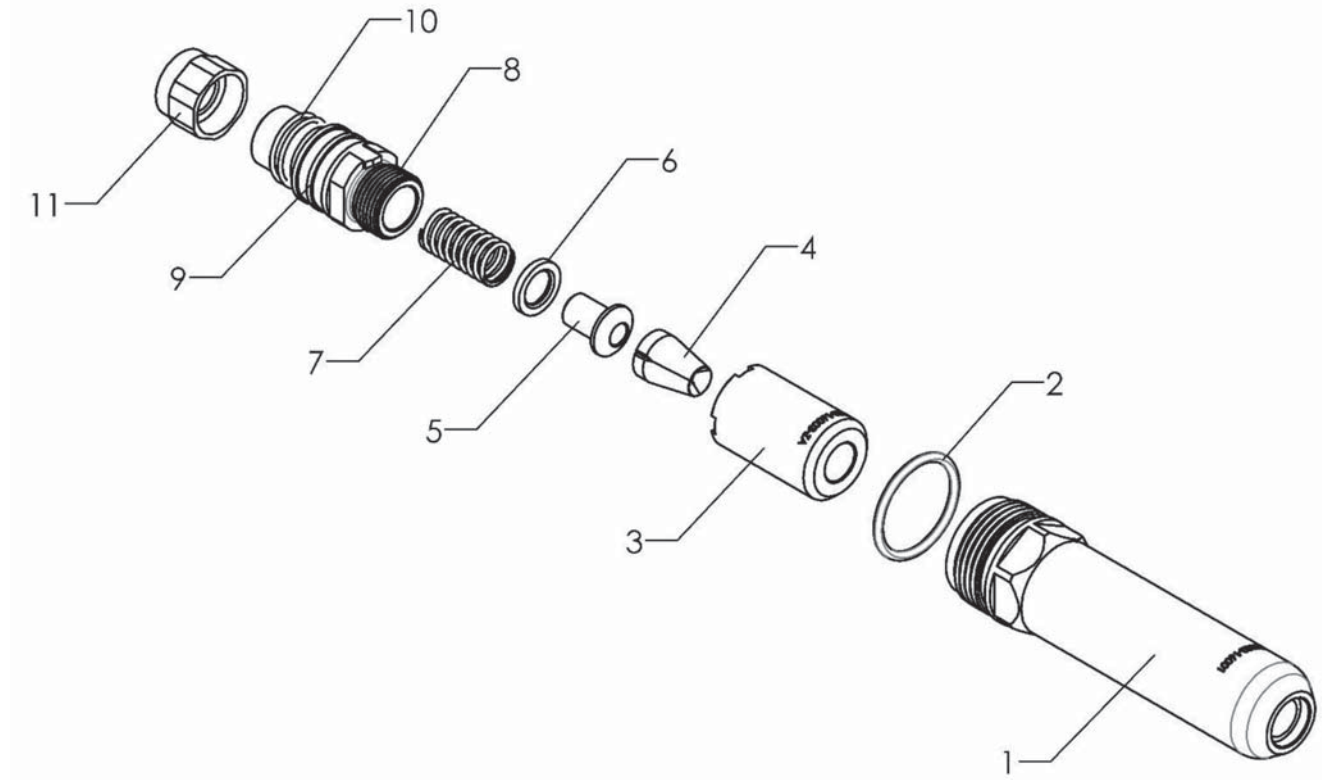

Part Number: 76002-16100			
Item	Part Number	Description	Qty
1	76002-16001	Nose Casing	1
2	TP144-091	O Ring	1
3	76002-16003	Jaw Guide	1
4	71210-16101	Jaws	1 Set
5	07498-04502	Jaw Spreader	1
6	71210-05001	Buffer	1
7	07500-00418	Jaw Spring	1
8	76002-16002	Pulling Head	1
9	TP144-051	Jaw Guide Lock	1
10	TP144-080	Jaw Guide Lock Spring	1
11	TP144-060	Lock Nut	1

**FITTING INSTRUCTIONS**

Item numbers in **bold** refer to nose assembly components in the tables and illustration above.

- The air supply must be disconnected.
- Remove the complete nose assembly TRM00361 as described in the ProSet® XT2 instruction manual.
- Screw Pulling Head (**8**) together with Jaw Guide Lock (**9**), Jaw Guide Lock Spring (**10**) to the tool piston and then tighten Lock Nut (**11**) to Pulling Head (**8**).
- Attach Jaw Spreader (**5**) together with Buffer (**6**) and Jaw Spring (**7**) to Pulling Head (**8**).
- Install Jaw Guide (**3**) together with Jaws (**4**) to Pulling Head (**8**).
- Screw Nose Casing (**1**) together with required Nosepiece and O-Ring (**2**) to Handle Upper.

- The tool is now ready to place Avseal rivets.

### **SERVICING INSTRUCTIONS**

- Nose Equipment need to be serviced at weekly intervals or every 3,000 cycles. Hold some stock of all internal components of Nose Equipment and Nosepieces, they need regular replacement.
- The air supply must be disconnected.
- Remove Nose Casing (1), including Nosepiece, and O-Ring (2) from the tool.
- Pull back Jaw Guide Lock (9) against Jaw Guide Lock Spring (10) and then remove Jaw Guide (3).
- Remove Jaws (4) from Jaw Guide (3).
- Remove Jaw Spreader (5), Buffer (6), and Jaw Spring (7), from Pulling Head (8).
- Rotate Lock Nut (11) anti-clockwise and remove Pulling Head (8), Jaw Guide Lock (9), Jaw Guide Lock Spring (10) from the tool piston using spanners.
- Inspect all components. Any worn or damaged parts must be replaced by a new part.
- Particularly check wear Jaws (4).
- Clean all parts and apply moly lithium Grease (07992-00020) to Jaws (4) and taper bore of Jaw Guide (3).
- Assemble according to fitting instructions above.

PROSET XT3 & XT4 NOSE ASSEMBLIES – 76003-16100, 76003-16200 & 76004-16100

**IMPORTANT**

Read the safety warnings listed in the ProSet® XT3 and ProSet® XT4 Instruction Manual carefully before putting into service.

**IMPORTANT**

The air supply must be turned off or disconnected before fitting or removing the nose assembly.

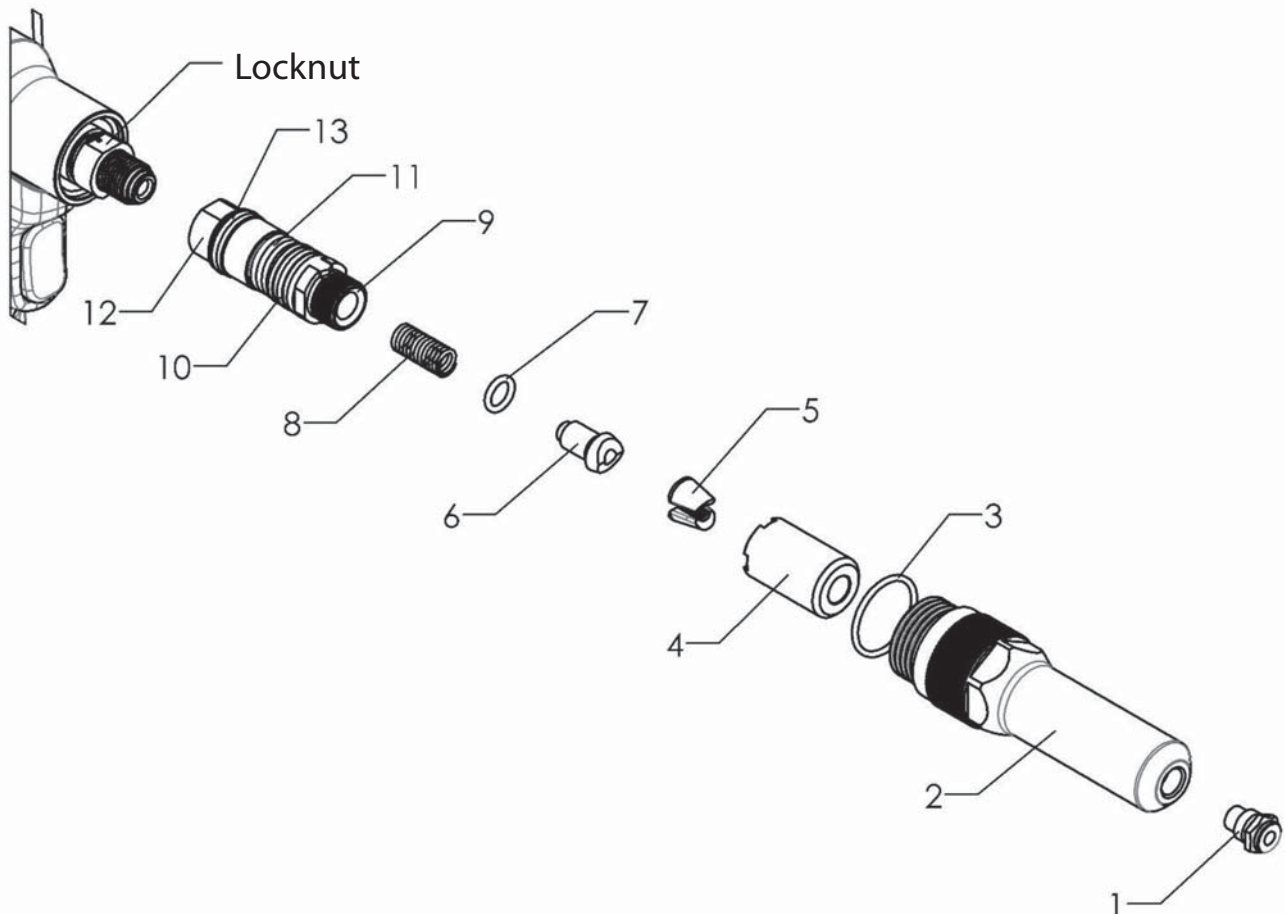

Part Number: 76003-16100			
Item	Part Number	Description	Qty
1	-	Nose Pieces - Supplied Separately	-
2	76003-16001	Nose Casing	1
3	07003-00067	O Ring	1
4	76003-16003	Jaw Guide	1
5	71210-16101	Jaws (3 pcs)	1 Set
6	07498-04502	Jaw Spreader	1
7	71210-05001	Buffer	1
8	07500-00418	Jaw Pusher Spring	1
9	76003-16002	Pulling Head	1
10	76003-15004	Jaw Guide Lock	1
11	DPN901-020	Spring	1
12	76003-15003	Pulling Head Adapter	1
13	07003-00277	O Ring	1

Part Number: 76003-16200			
Item	Part Number	Description	Qty
1	-	Nose Pieces - Supplied Separately	-
2	76003-16001	Nose Casing	1
3	07003-00067	O Ring	1
4	76003-16203	Jaw Guide	1
5	71220-16120	Jaws (3 pcs)	1 Set
6	07498-04502	Jaw Spreader	1
7	07498-03003	Buffer	1
8	07500-00418	Jaw Pusher Spring	1
9	76003-16002	Pulling Head	1
10	76003-15004	Jaw Guide Lock	1
11	DPN901-020	Spring	1
12	76003-15003	Pulling Head Adapter	1
13	07003-00277	O Ring	1

Part Number: 76004-16100			
Item	Part Number	Description	Qty
1	-	Nose Pieces - Supplied Separately	-
2	76003-16001	Nose Casing	1
3	07003-00067	O Ring	1
4	76003-16203	Jaw Guide	1
5	71230-16101	Jaws (3 pcs)	1 Set
6	07498-04502	Jaw Spreader	1
7	07498-03003	Buffer	1
8	07500-00418	Jaw Pusher Spring	1
9	76003-16002	Pulling Head	1
10	76003-15004	Jaw Guide Lock	1
11	DPN901-020	Spring	1
12	76003-15003	Pulling Head Adapter	1
13	07003-00277	O Ring	1

## FITTING INSTRUCTIONS

Item numbers in **bold** refer to nose assembly components in the tables and illustration above.

- The air supply must be disconnected.
- If necessary, remove the complete nose assembly 76003-15000 as described in the ProSet® XT3 and ProSet® XT4 instruction manual.
- Lightly coat jaws (**5**) with moly lithium grease.
- Drop Jaws (**5**) into the jaw guide (**4**).
- Insert the jaw pusher spring (**8**), jaw pusher or jaw spreader (**6**) and O ring or buffer (**7**) into the pulling head (**9**).
- Pull back the jaw guide lock (**10**) and screw the jaw guide (**4**) fully on to the pulling head (**9**).
- Release the jaw guide lock (**10**) and then partially unscrew the jaw guide (**4**) until the jaw guide lock (**10**) tooth clicks into the next slot on the jaw guide (**4**).
- Attach the pulling head assembly, Jaws Guide, Jaws, Jaw Pusher, Buffer and Spring (**4, 5, 6, 7, 8, 9, 10, 11, 12 & 13**) to the tool piston and then tighten the locknut (71210-02103) against it using spanners.
- Place nose casing (**2**) over the jaw guide (**4**) and tighten fully onto the tool.
- Nose tips (**1**) should be installed in the Nose Casing (**2**) and tightened to a torque of 7.0 – 7.5 Nm.
- If required, apply Loctite 932 on the Nose Tip (**1**) thread to prevent the part from coming loose in use.

## SERVICING INSTRUCTIONS

- Nose assemblies need to be serviced at weekly intervals or every 5,000 cycles. Hold some stock of all internal components of the nose assembly and nose pieces, they need regular replacement.
- The air supply must be disconnected.
- Remove the nose casing (**2**), including the nose piece (**1**), and O ring (**3**) from the tool.
- Pull back the jaw guide lock (**10**) against the spring (**11**) and then remove the jaw guide (**4**).
- Remove the jaws (**5**) from the jaw guide (**4**).
- Remove jaw pusher or jaw spreader (**6**), O ring or buffer (**7**), and Jaw pusher spring (**8**), from the pulling head (**9**).
- Remove the pulling head assembly (**9, 10, 11, 12 & 13**) from the tool piston using spanners
- Inspect all components. Any worn or damaged parts must be replaced by a new part.
- Particularly check wear on the Jaws (**5**).
- Clean all parts and apply moly lithium Grease (07992-00020) to jaws (**5**) and taper bore of jaw guide (**4**).
- Assemble according to fitting instructions above.

*PROSET XT3 & XT4 NOSE ASSEMBLIES – 71210-16100, 71220-16100 & 71230-16100*

**IMPORTANT**

Read the safety warnings listed in the ProSet® XT3 and ProSet® XT4 Instruction Manual carefully before putting into service.

**IMPORTANT**

The air supply must be turned off or disconnected before fitting or removing the nose assembly.

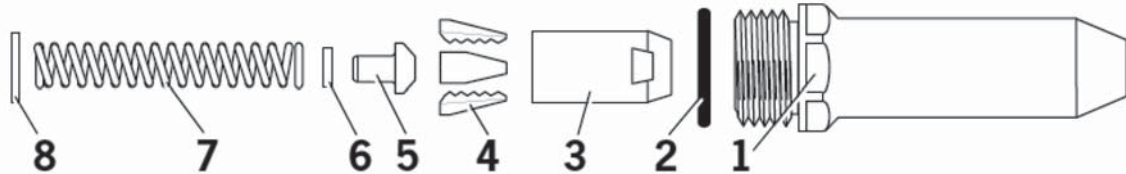

Part Number: 71210-16100				Part Number: 71230-16100			
Item	Part Number	Description	Qty	Item	Part Number	Description	Qty
1	07340-00306	Nose Casing	1	1	07340-00306	Nose Casing	1
2	07003-00067	O Ring	1	2	07003-00067	O Ring	1
3	07340-00304	Jaw Housing	1	3	07612-02003	Jaw Housing	1
4	71210-16101	Jaws (3 pcs)	1 Set	4	71230-16101	Jaws (3 pcs)	1 Set
5	07498-04502	Jaw Spreader	1	5	07498-04502	Jaw Spreader	1
6	71210-05001	Buffer	1	6	07498-03003	Buffer	1
7	07500-00418	Jaw Pusher Spring	1	7	07500-00418	Jaw Pusher Spring	1
8	07340-00327	Locking Ring	1	8	07340-00327	Locking Ring	1

Part Number: 71220-16100			
Item	Part Number	Description	Qty
1	07340-00306	Nose Casing	1
2	07003-00067	O Ring	1
3	07612-02003	Jaw Housing	1
4	71220-16120	Jaws (3 pcs)	1 Set
5	07498-04502	Jaw Spreader	1
6	07498-03003	Buffer	1
7	07500-00418	Jaw Pusher Spring	1
8	07340-00327	Locking Ring	1

**FITTING INSTRUCTIONS**

Item numbers in **bold** refer to nose assembly components in the tables and diagram above.

- The air supply must be disconnected.
- If necessary, remove the complete nose assembly 76003-15000 as described in the ProSet® XT3 and ProSet® XT4 instruction manual.
- Fit the XT3 Adapter Kit 76003-20400 to the tool piston and then tighten the locknut (71210-02103) against it using spanners.
- Lightly coat Jaws (**4**) with Moly Lithium grease\*.
- Drop Jaws (**4**) into Jaw Housing (**3**).
- Insert Jaw Spreader (**5**) into Jaw Housing (**3**).
- Locate Buffer (**6**) on Jaw Spreader (**5**).
- Locate Spring (**7**) onto Jaw Spreader (**5**).
- Fit Locking Ring (**8**) onto the jaw spreader housing from XT3 Adapter Kit 76003-20400.
- Holding tool pointing down, screw the assembled jaw housing onto the jaw spreader housing and tighten with spanner.
- Screw the nose tip into Nose Casing (**1**) and tighten with spanner.
- Place Nose Casing (**1**) with O Ring (**2**) over Jaw Housing (**3**) and screw onto the tool, tightening with spanner.



**SERVICING INSTRUCTIONS**

- Nose assemblies need to be serviced at weekly intervals or every 5,000 cycles. Hold some stock of all internal components of the nose assembly and nose pieces, they need regular replacement.
- The air supply must be disconnected.
- Remove the nose assembly using the reverse procedure to the 'Fitting Instructions'.
- Any worn or damaged part should be replaced.
- Clean and check wear on jaws.
- Ensure that the jaw spreader is not distorted.
- Check that the spring is not distorted.
- Assemble according to fitting instructions.

*PB2500 & PB3400 NOSE ASSEMBLIES – 71701-16200, 71701-16300 & 71702-16200*

**IMPORTANT**

Read the safety warnings listed in the PB2500 and PB3400 Instruction Manual carefully before putting into service.

**IMPORTANT**

The battery must be disconnected before fitting or removing the nose assembly.

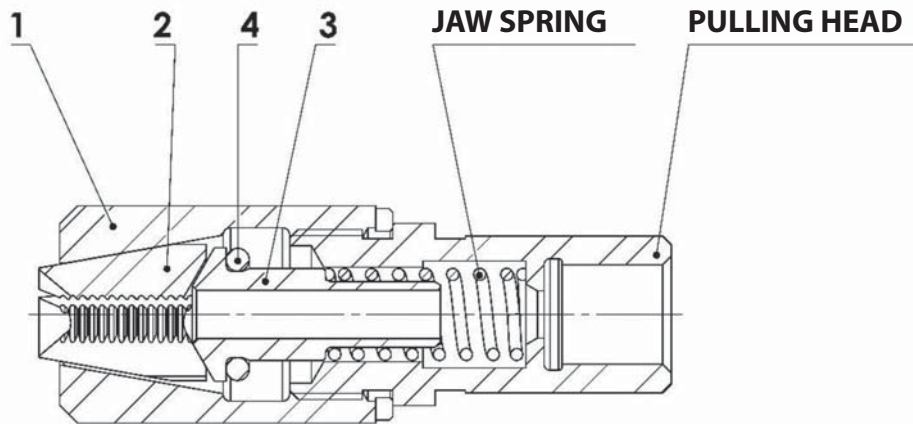

Part Number: 71701-16200			
Item	Part Number	Description	Qty
1	71701-16231	Jaw Guide	1
2	71210-16101	Jaws (3 pcs)	1set
3	71701-16232	Jaw Pusher	1
4	TP124-501	O Ring	1

Part Number: 71701-16300			
Item	Part Number	Description	Qty
1	71701-16001	Jaw Guide	1
2	71220-16120	Jaws (3 pcs)	1set
3	71701-16015	Jaw Pusher Assembly	1

Part Number: 71702-16200			
Item	Part Number	Description	Qty
1	71702-16001	Jaw Guide	1
2	71210-16101	Jaws (3 pcs)	1set
3	71702-16039	Jaw Pusher Assembly	1

**FITTING INSTRUCTIONS**

Item numbers in **bold** refer to nose assembly components in the tables and diagram above.

- The battery must be disconnected.
- The Nose Housing, Jaw Spring and Pulling Head supplied with the PB2500 and PB3400 tools and will need to be used together with the Avseal II nose assembly parts listed above.
- The standard Jaws, Jaw Guide & Jaw Pusher supplied with the PB2500 and PB3400 tools will need to be exchanged with the parts listed in the above table.
- Remove the Nose Housing from the tool as described in the PB2500 and PB3400 instruction manual.
- Unscrew and remove the standard Jaw Guide, Jaws and Jaw Pusher from the Pulling Head.
- Lightly coat jaws (**3**) with moly lithium grease.
- Drop Jaws (**3**) into the jaw guide (**1**).
- Insert the jaw pusher spring, jaw pusher assembly (**3**) and o ring (**4**) into the pulling head.
- Attach the jaw guide (**1**) and jaws (**2**) on to the pulling head.
- Do NOT use spanners to mount jaw guide (**1**) onto front clutch of the PB2500 and PB3400 tools. Manual tightening of the Jaw guide (**1**) is enough to lock onto front clutch.
- Screw the nose tip into Nose Housing and tighten with a spanner.
- Place Nose housing over Jaw Guide (**1**) and screw fully onto the PB2500 and PB3400 tools.

**SERVICING INSTRUCTIONS**

- Nose assemblies need to be serviced at weekly intervals or every 5,000 cycles. Hold some stock of all internal components of the nose assembly and nose pieces, they need regular replacement.
- The battery must be disconnected.

- 
- Remove the nose housing, including the nose piece from the tool.
  - Pull back the front clutch and then remove the jaw guide (1).
  - Remove the jaws (2) from the jaw guide (1).
  - Remove jaw pusher (2) and Jaw spring, from the pulling head.
  - Inspect all components. Any worn or damaged parts must be replaced by a new part.
  - Particularly check wear on the Jaws (2).
  - Clean all parts and apply moly lithium Grease (07992-00020) to jaws (2) and taper bore of jaw guide (1).
  - Assemble according to fitting instructions above.

7287 & AV<sup>5</sup> NOSE ASSEMBLIES – 07220-06700**IMPORTANT**

Read the safety warnings listed in the 7287 and AV<sup>5</sup> Instruction Manual carefully before putting into service.

**IMPORTANT**

The air supply and hydraulic supply must be turned off or disconnected before fitting or removing the nose assembly.

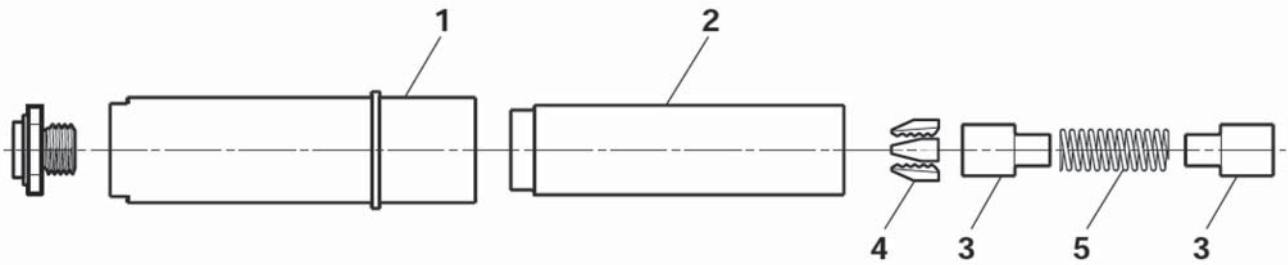

Part Number: 7220-06700			
Item	Part Number	Description	Qty
1	07220-06601	Nose Casing	1
2	07220-06602	Jaw Housing	1
3	07220-06603	Spring Guide	2
4	07220-06501	Jaws	1 Set
5	07500-02005	Spring	1

**FITTING INSTRUCTIONS**

Item numbers in **bold** refer to nose assembly components in the tables and diagram above.

- The air supply and hydraulic supply must be disconnected.
- Lightly coat Jaws (**4**) with Moly lithium grease.
- Assemble Spring Guides (**3**) and Spring (**5**) and stand on end on a flat even surface.
- Balance the three Jaws (**4**) on the upper Spring Guide (**3**).
- Carefully lower Jaw Housing (**2**) over the assembled components.
- Holding tool pointing down, screw the assembled jaw housing onto the tool head piston and tighten with spanner.
- Screw the nose tip into Nose Casing (**1**) and tighten with spanner.
- Place the Adapter Ring over the rear of the Nose Casing (**1**), ensuring that the lugs on the body enter the slots in the Adapter Ring.
- Place Nose Casing (**1**) and Adapter Ring over the Jaw Housing (**2**) and onto the tool.
- Place the Retaining Nut from the tool over the Nose Casing (**1**), attach to the tool and tighten with a spanner.

**SERVICING INSTRUCTIONS**

- Nose assemblies should be serviced at weekly intervals. You should hold some stock of all internal components of the nose assembly and nose tips as they will need regular replacement.
- Remove the nose assembly using the reverse procedure to the 'Fitting instructions'.
- Any worn or damaged parts should be replaced.
- Clean and check wear on jaws.
- Check that the spring and spring guides are not distorted.
- Clean and inspect components, renewing worn or damaged items.
- Assemble according to fitting instructions.







**STANLEY**  
Engineered Fastening

**STANLEY Engineered Fastening**

STANLEY House, Works Road  
Letchworth Garden City  
Hertfordshire, United Kingdom  
SG6 1JY  
Tel: +44 1582 900 000  
Fax: +44 1582 900 001



**Holding your world together®**

Find your closest STANLEY Engineered Fastening location on  
[www.stanleyEngineeredFastening.com/contact](http://www.stanleyEngineeredFastening.com/contact)  
For an authorized distributor nearby please check

[www.stanleyEngineeredFastening.com/econtact/distributors](http://www.stanleyEngineeredFastening.com/econtact/distributors)

Manual Number	Issue	C/N
07900-09432	A	20/052

**STANLEY**  
Assembly Technologies

Stanley Engineered Fastening — a division of Stanley Black and Decker — is the global leader in precision fastening and assembly solutions. Our industry-leading brands, Avdel®, Integra™, Nelson®, Optia™, POP®, Stanley™ Assembly Technologies, and Tucker®, elevate what our customers create. Backed by a team of passionate and responsive problem-solvers, we empower engineers who are changing the world.

**STANLEY ENGINEERED FASTENING FAMILY OF BRANDS**

**AVDEL**    **INTEGRA™**    **NELSON®**    **OPTIA™**    **POP®**    **STANLEY**  
Assembly Technologies    **TUCKER®**