

NELSON[®] **STUD WELDING**

A Nelson Fastener Systems Company

Stud, Ferrule & Accessory Catalog



September 2017

www.NelsonStud.com

2017 Nelson® Stud Welding Stud, Ferrule & Accessory Catalog

This catalog is designed to be a user-friendly source of online information about the Nelson Stud Welding line of studs, anchors, pins, and the standard accessories used to weld them. Many features have been incorporated into the pages of this catalog to enable you, the customer, to find the information you need quickly and easily.

Many studs, pins, anchors, and ferrules are featured to provide the greatest range of possible solutions to your stud welding applications.

✓ **Bookmarks have been added to make navigation through the catalog quick and easy.**

- Text explanations have been added to clarify some of the potential uses of each stud.
- Suggestions for similar use studs will assist you in making the correct stud choice for your stud welding application.
- PDF format creates a quicker downloading, more informative catalog that is readable on both IBM and Macintosh platforms. Security features assure that the information you download from our web site is genuine Nelson information.
- Links embedded in each page take you right to the information you need, making the stud information more easily accessible.
- Detailed ferrule and accessory information allows you to identify and specify the exact parts you need to execute the job.
- Clickable table of contents and indexes quickly locates the stud information you need.
- Studs are indexed by welding process and use in industry to make finding the stud you need faster and easier.
- Company contact information is provided on every specification sheet to make communication with Nelson Stud Welding faster than ever before!

Your questions, comments, and suggestions are welcome and appreciated. Please follow the bookmark at left.

Thank you for choosing to download this catalog. We think you will find it the most useful and informative method to explore the [Nelson Stud Welding product line](#).

Using the 2017 Nelson Stud Welding, Inc. Electronic Catalog

© 2017, Nelson Stud Welding, Inc., All rights reserved

All information contained herein is the property of Nelson Stud Welding, Inc. and is intended for the use of our customers. This information pertains solely to Nelson studs and related accessories. Use of this information in conjunction with non-Nelson studs and related accessories is not recommended by Nelson Stud Welding, Inc. Nelson Stud Welding, Inc. assumes no financial or physical responsibility for damage or harm resulting from this information's use with non-Nelson studs and related accessories. No part of this publication (whether in hard copy or electronic form) may be reproduced or transmitted, in any form or by any means, electronic, mechanical, photocopying, recording, or otherwise, without prior written consent of Nelson Stud Welding, Inc.

Stored Arc™ and Tranquil Arc™ are registered trademarks of Nelson Stud Welding, Inc. All instances of the names Stored Arc™ or Tranquil Arc™ in the text are references to the Stored Arc™ stud welding process or Tranquil Arc™ accessory kit, as defined by Nelson Stud Welding, Inc., unless otherwise indicated.

CrimpLok™ and Setlok™ are registered trademarks of Nelson Stud Welding, Inc. All instances of the names CrimpLok™ or Setlok™ in the text are references to the CrimpLok™ style of cable hangers or Setlok™ studs and caps, as defined by Nelson Stud Welding, Inc., unless otherwise indicated.

- The Nelson name, logos, and the Nelson eagle are all trademarks of Nelson Stud Welding, Inc. Adobe and Adobe Acrobat are trademarks of Adobe Systems Incorporated.
- All other trademarks or name brands are trademarks of their respective holders.

This publication and the information herein is furnished AS IS, is subject to change without notice, and should not be construed as a commitment by Nelson Stud Welding, Inc. Nelson Stud Welding, Inc. assumes no responsibility or liability for any errors or inaccuracies, makes no warranty of any kind (express, implied, or statutory) with respect to this publication, and expressly disclaims any and all warranties of merchantability, fitness for particular purposes, and non-infringement of third party rights.

GENERAL MATERIAL SPECIFICATIONS.....	8
MILD STEEL.....	8
STAINLESS STEEL	8
MECHANICAL PROPERTIES - STANDARD	8
MECHANICAL PROPERTIES - METRIC	8
ALUMINUM.....	9
<i>Mechanical Properties – Standard</i>	9
<i>Mechanical Properties - Metric</i>	9
GENERAL STUD SPECIFICATIONS.....	10
COLD HEADING	10
STANDARD ARC WELDING STUDS (AWS TYPE A) —TENSILE AND TORQUE STRENGTHS.....	11
<i>Mild Steel – 61,000psi Minimum Ultimate, 49,000 psi Minimum Yield</i>	11
<i>Stainless Steel (As Formed) – 70,000 psi Minimum Ultimate, 35,000 psi Minimum Yield</i>	12
HIGH STRENGTH STEEL – 110,000 [†] PSI MINIMUM ULTIMATE, 92,000 PSI MINIMUM YIELD	13
STORED ARC WELDING STUDS—TENSILE/YIELD STRENGTHS	13
STUD DIMENSIONS	14
THREADS	14
FLUX	14
PLATING	14
ANNEALING.....	14
FERRULES.....	14
ACCESSORIES	15
WELD FLASH	15
ORDERING	15
WEIGHT CHARTS FOR SHIPPING.....	15
<i>Threaded Studs</i>	15
<i>Unthreaded Studs</i>	16
<i>Shear Connectors</i>	17
<i>Headed Anchors</i>	17
INSULATION FASTENER QUANTITIES	18
DELIVERIES.....	18
EXTRA CHARGES.....	18
STUDS.....	19
EXTERNALLY THREADED	19
<i>B5L 90° Bent Collar Studs</i>	19
<i>CFL Fully Threaded Studs</i>	20
<i>CPL Partially Threaded Studs</i>	21
<i>CFP, CPP, FFP, FPP Small Diameter Threaded Studs</i>	22
<i>HBL Full Base Diameter Threaded Studs</i>	23
<i>CKL Collar Studs</i>	24
<i>SBL and VBL Shoulder Studs</i>	25
<i>CJL Reduced Base Studs</i>	26
<i>Watertight Nuts</i>	27
INTERNALLY THREADED.....	28
<i>TBL and PBL Internally Threaded Studs</i>	28
<i>S6L Sprinkler Studs</i>	29
CONCRETE ANCHORS.....	30
<i>S3L Shear Connectors</i>	30
<i>H4L Headed Concrete Anchors</i>	31
<i>D2L Headed Concrete Anchors</i>	32
<i>PSRS</i>	33
HIGH STRENGTH STUDS	34
<i>High Strength Pitch Base</i>	34
UNTHREADED	35
<i>NBL Unthreaded Studs</i>	35

	5
<i>B4L and B4P Reinforcing Standoff Support Studs</i>	36
<i>R9L Rope Hook Studs</i>	37
<i>XBL and XXL Round Corner Square Studs</i>	38
<i>J2L “J” Bolt Studs</i>	39
<i>E2L “Eyebolt” Studs</i>	40
<i>NJL Reduced Base Unthreaded Studs</i>	41
<i>S2L Setlok Studs</i>	42
Setlok Caps and Speed Clips.....	42
METRIC DRAWN ARC	43
<i>MP Partially Threaded Studs</i>	43
<i>MPF Threaded Studs</i>	44
<i>MD Fully Threaded Studs</i>	45
<i>MR Reduced Base Studs</i>	46
<i>CKL Collar Studs</i>	47
<i>NBL Unthreaded Studs</i>	48
<i>Metric TBL Internally Threaded Studs</i>	49
AUTOMOTIVE	50
<i>AXC “Fir Tree” Studs</i>	50
<i>Grounding Studs</i>	51
<i>H8X “T” Studs</i>	52
<i>“W” Top Wide Flange Studs</i>	53
SHORT CYCLE / STORED ARC.....	54
<i>ANC, ANS, and ANA Unthreaded Stored Arc Studs</i>	54
<i>ATC, ATS, and ATA Threaded Stored Arc Studs</i>	55
METRIC SHORT CYCLE / STORED ARC	56
<i>ATC, ATS, and ATA Threaded Studs</i>	56
<i>ANC, ANS, and ANA Unthreaded Studs</i>	57
CAPACITOR DISCHARGE	58
<i>TATC, TATS, TATA Auto-Feed Threaded Capacitor Discharge Studs</i>	58
<i>TFNC, TFNS, and TFNA Flanged Unthreaded Capacitor Discharge Studs</i>	59
<i>TFTC, TFTS, and TFTA Flanged Threaded Capacitor Discharge Studs</i>	60
<i>TUTC, TUTS, and TUTA Unflanged Threaded Capacitor Discharge Studs</i>	61
METRIC CAPACITOR DISCHARGE	62
<i>TFNC, TFNS, TFNA Flanged Unthreaded Studs</i>	62
<i>TFTC, TFTS, TFTA Flanged Threaded CD Studs</i>	63
ALUMINUM DRAWN ARC.....	64
<i>HBA Full Base Threaded Aluminum Studs</i>	64
<i>CKA Aluminum Collar Studs</i>	65
<i>NBA Unthreaded Aluminum Studs</i>	66
<i>SBA Threaded Aluminum Shoulder Studs</i>	67
<i>TBA Internally Threaded Aluminum Studs</i>	68
<i>N3A Aluminum Navy Type Annular Pins</i>	69
Cap for N3A and N3P Pins	69
CABLE HANGERS FOR STUD WELDING	70
<i>CrimpLok™ Cable Hangers</i>	70
<i>Banding Style Cable Hangers</i>	71
REFRACTORY ANCHORS FOR STUD WELDING	72
<i>F3L Flanged Collar Studs</i>	72
<i>L2L Lagging Studs with Hole</i>	73
<i>S4X “Y” Refractory Anchor Studs</i>	74
<i>S7X Steerhorn Refractory Anchor Studs</i>	75
RECTANGULAR STUDS.....	76
<i>R1P and R1L Rectangular Stud without Hole</i>	76
<i>R2P Rectangular Notched Stud</i>	77
<i>R5P Strand Support Stud</i>	78
<i>R6P Rectangular Slotted Stud</i>	79
<i>R7P Rectangular Slotted Stud</i>	80
<i>RWP Wiggley Strand Support Stud</i>	81

	6
<i>RXX FiberLok™ Stud</i>	82
Fiberlok™ Washer	82
INSULATION PINS.....	83
<i>CHP Cupped Head Insulation Pins</i>	83
<i>N3P Navy Type Annular Ring Studs</i>	84
Cap for N3A and N3P Pins	84
<i>P2P Double Pointed Insulation Pin</i>	85
Speed Clips.....	85
<i>TPC Single Pointed Insulation Pin</i>	86
Speed Clips.....	86
FERRULES	87
STANDARD FERRULES	87
<i>Full Base</i>	87
<i>Full Base – Thin Wall</i>	87
<i>Full Base – Low Profile, F-139</i>	88
<i>Threaded Pitch Diameter, F-239</i>	88
<i>Full Threaded, F-107</i>	88
<i>Collar Studs, F-172</i>	89
<i>Reduced Base, F-106</i>	89
<i>Aluminum Ferrules</i>	89
SPECIAL FERRULES	90
<i>Low Profile</i>	90
<i>Special Collar</i>	90
<i>Special Short CFL, Full Threaded</i>	90
<i>Non-Skid, Heavy Duty</i>	90
<i>Short, Heavy Duty</i>	90
<i>3/4 Special, Small Vent</i>	90
<i>Special</i>	90
SPECIAL APPLICATIONS	91
<i>Special Ferrule for Welding at an Angle to a Base Plate</i>	91
<i>Special Concave Ferrules for Welding to Curved Surfaces</i>	92
<i>Welding to Edges of Base Plates</i>	93
<i>Special Ferrule for Welding into Fillets and Onto Heels</i>	94
<i>Special Ferrules for Stripping Straight Off Headed Studs</i>	95
<i>Special Ferrules for Welding to Vertical Surfaces</i>	96
<i>Special Ferrules for Welding Through metal Deck</i>	97
RECTANGULAR FERRULES	98
DOUBLE REDUCED BASE STUDS.....	99
REFRACTORY ANCHOR FERRULES	100
ACCESSORIES	101
CHUCKS.....	101
<i>Stud Weld Gun Imperial Dimension Chucks</i>	101
<i>Stud Weld Gun Imperial Dimension Chucks (Continued)</i>	102
<i>Stud Weld Gun Metric Dimension Chucks</i>	103
<i>Long Style Chucks</i>	104
<i>Male Style and Extensions</i>	105
<i>Rectangular, Square, Internal, Bent, and Side Gripping</i>	106
<i>Capacitor Discharge Weld Gun Chucks</i>	107
<i>Screw-On Chucks and Extensions to Reach into Ferrule Tubing & Holes</i>	108
FEET	109
<i>Standard Closed Feet</i>	109
<i>Standard Split or Open Feet</i>	109
<i>Shear Connector and Gas Feet</i>	109
FERRULE GRIPS AND FERRULE HOLDERS.....	110
<i>Small Copper Ferrule Grips</i>	110
<i>Medium Copper Ferrule Grips</i>	111

Larger Copper Ferrule Grips 111

MISCELLANEOUS STUD WELDING ACCESSORIES..... 112

MISCELLANEOUS CAPACITOR DISCHARGE ACCESSORIES..... 113

MISCELLANEOUS STORED ARC ACCESSORIES 114

General Material Specifications

Material Specifications

Nelson's studs may be made of one of the following materials, as specified on individual specification sheets. Certificates of chemical analysis and physical properties are available, upon request. All physical and chemical properties are independent of stud size or shape.

Mild Steel

Standard mild steel studs manufactured by Nelson conform to ASTM A29 chemistry specifications for grades 1010 through 1020 mild steels. Physical properties of mild steel Nelson studs are in accordance with AWS D1.1. Special studs can also be manufactured of other weldable mild steels. Heat treatments and plating can be applied to mild steel studs, upon request.

Mild Steel Chemical Composition

Element	Minimum wt%	Maximum wt%
C	0.08	0.23
Mn	0.30	0.90
P	--	0.04
S	--	0.05

Stainless Steel

Standard Nelson studs manufactured of stainless steel conform to ASTM A276 or A493 specifications. Studs can be manufactured from other weldable stainless steel alloys. Mechanical properties of Nelson stainless steel studs depend on the cold working or heat treatment applied to the studs after forming. Stainless steel studs can be annealed, upon request.

Stainless Steel Chemical Composition

Element	UNS 30430 (302HQ)		UNS 30403 (304L)		UNS 31603 (316L)	
	Minimum wt%	Maximum wt%	Minimum wt%	Maximum wt%	Minimum wt%	Maximum wt%
C	--	0.08	--	0.03	--	0.03
Cr	17.00	19.00	18.00	20.00	16.00	18.00
Ni	8.00	10.00	8.00	12.00	10.00	14.00
Mn	--	2.00	--	2.00	--	2.00
Cu	3.00	4.00	--	--	--	--

Mechanical Properties - Standard

<i>Minimum Values</i>	Mild Steel Shear and Concrete Anchors <i>AWS Type B</i>	Standard Mild Steel Studs <i>AWS Type A</i>	Mild Steel Deformed Bar Anchors <i>AWS Type C</i>	Stainless Steel Studs, as formed <i>AWS D1.6</i>
Ultimate Tensile (psi), Rm	65,000	61,000	80,000	70,000
Yield, 0.2% offset (psi), Re	51,000	49,000	70,000	35,000
% Elongation, A5, in 2" gage length	20	17	N/A	40
% Area Reduction (min)	50	50	N/A	N/A

Mechanical Properties - Metric

<i>Minimum Values</i>	Mild Steel Shear and Concrete Anchors <i>AWS Type B</i>	Standard Mild Steel Studs <i>AWS Type A</i>	Mild Steel Deformed Bar Anchors <i>AWS Type C</i>	Stainless Steel Studs, as formed <i>AWS D1.6</i>
Ultimate Tensile (MPa), Rm	448	420	551	482
Yield, 0.2% offset (MPa), Re	351	337	482	241
% Elongation, A5, in 2" gage length	20	17	N/A	40
% Area Reduction (min)	50	50	N/A	N/A

General Material Specifications

Aluminum

Nelson manufactured aluminum studs are made from Aluminum Association (AA) alloys 1100, 5086, 5356, and 6061. Aluminum studs can be annealed upon request. The chemical composition and physical properties of these alloys are shown below.

Aluminum Alloy Chemical Composition

Element	Gas Arc, Stored Arc		Drawn				Capacitor Discharge Only ¹	
	Alloy 1100 ASTM B211		Alloy 5356		Alloy 5086 ASTM B211		Alloy 6061 ASTM B211	
	Minimum wt%	Maximum wt%	Minimum wt%	Maximum wt%	Minimum wt%	Maximum wt%	Minimum wt%	Maximum wt%
Al	99	--	93.05	95.34	93.15	96.25	96.00	98.61
Cr	--	--	0.05	0.20	0.05	0.25	0.04	0.35
Cu	0.05	0.20	--	0.10	--	0.10	0.15	0.4
Mn	--	0.05	0.05	0.20	0.20	0.70	--	0.15
Si	N/A	N/A	--	0.25	--	0.40	0.40	0.80
Fe	N/A	N/A	--	0.40	--	0.50	--	0.70
Si+Fe	--	0.95	N/A	N/A	N/A	N/A	N/A	N/A
Zn	--	0.10	--	0.10	--	0.25	--	0.25
Mg	--	--	4.50	5.50	3.50	4.50	0.80	1.20
Ti	--	--	0.06	0.20	--	0.15	--	0.15

Mechanical Properties – Standard

Minimum Values	1100 H-16	5356 H-32	5086 H-32	6061- T-6
Ultimate Tensile (psi), Rm	21,000	46,000	42,000	45,000
Yield, 0.2% offset (MPa), Re	20,000	32,000	30,000	40,000
% Elongation, A5, in 2" gage length	17	24	12	17
% Area Reduction	N/A	N/A	N/A	N/A

Mechanical Properties - Metric

Minimum Values	1100 H-16	5356 H-32	5086 H-32	6061- T-6
Ultimate Tensile (psi), Rm	144	317	289	310
Yield, 0.2% offset (MPa), Re	137	220	206	275
% Elongation, A5, in 2" gage length	17	24	12	17
% Area Reduction	N/A	N/A	N/A	N/A

¹TPA insulation pins are Alloy 1100

General Stud Specifications

Cold Heading

The primary method used by Nelson to produce stud welded fasteners is the Cold Forming process. Utilizing the same cold heading production equipment, Nelson produces an extensive line of non-welded, cold-formed parts. These parts can be custom designed to satisfy the specific requirements of individual customers.

Pictured at right are just some of the many different cold-formed parts and shapes that Nelson is capable of producing. If you are currently purchasing cold-formed or screw-machined parts, Nelson may be able to offer cost savings and quality improvements.

To understand Nelson's capabilities and to determine if cold forming will benefit you, consult the following specification:



Should You Inquire About Nelson's Cold Forming Capability? *The answer is YES if*

- Your part is 1" or less in diameter, and the shank diameter is 1" or less, and the length is less than 15"
- Your part is assembled from several components
- Your annual part volume is 100,000 pieces or more
- You currently experience substantial material waste
- You require closer tolerances
- You need greater process control capability (higher CPK)
- You desire greater part strength and/or better surface finish is desired
- You have not shopped your part cost in several years

Nelson's Capabilities

- Wire diameter ranging from 1/8" (0.125") through 1"
- Upset forming diameters up to 225% of wire diameter
- Cut-off length up to 15"
- Up to five dies and hammers can be used to progressively form complex shapes
- Upsets, forward and backward extrusions, punched and through holes, flanges, collars, heads, and other forming techniques can be accommodated
- Production rates from 45 to 450 pieces per minute
- Complete secondary operations
- In-house tool and die design and fabrication

Submit the following information for a FREE Cost Quotation:

- Part drawing with critical dimensions
- Order quantity and annual volume
- A sample of the part you are currently purchasing
- Your target pricing

General Stud Specifications

Standard Arc Welding Studs (AWS Type A) — Tensile and Torque Strengths

Mild Steel – 61,000psi Minimum Ultimate, 49,000 psi Minimum Yield

Thread Diameter	META ¹ (sq. in.)	Yield Load ² (lbs.) at 49,000 psi	Ultimate Tensile Load (lbs) at 61,000 psi	Yield Torque ² (ft-lbs) at 49,000 psi	Ultimate Torque (ft-lbs) at 61,000 psi	Shear Strength (75% of Tensile Strength)
10-24 UNC	0.0174	853	1,061	2.7	3.4	796
10-32 UNF	0.0199	975	1,214	3.1	3.8	910
1/4-20 UNC	0.0317	1,553	1,934	6.5	8.1	1,450
1/4-28 UNF	0.0362	1,774	2,208	7.4	9.2	1,656
5/16-18 UNC	0.0522	2,558	3,184	13.3	16.6	2,388
5/16-24 UNF	0.0579	2,837	3,532	14.8	18.4	2,649
3/8-16 UNC	0.0773	3,788	4,715	23.7	29.5	3,536
3/8-24 UNF	0.0876	4,292	5,344	26.8	33.4	4,008
7/16-14 UNC	0.1060	5,194	6,466	37.9	47.1	4,850
7/16-20 UNF	0.1185	5,807	7,229	42.3	52.7	5,421
1/2-13 UNC	0.1416	6,938	8,638	57.8	72.0	6,478
1/2-20 UNF	0.1597	7,825	9,742	65.2	81.2	7,306
5/8-11 UNC	0.2256	11,054	13,762	115.2	143.4	10,321
5/8-18 UNF	0.2555	12,520	15,586	130.4	162.3	11,689
3/4-10 UNC	0.3340	16,366	20,374	204.6	254.7	15,281
3/4-16 UNF	0.3724	18,248	22,716	228.1	284.0	17,037
7/8-9 UNC	0.4612	22,599	28,133	329.6	410.3	21,100
7/8-14 UNF	0.5088	24,931	31,037	363.6	452.6	23,278
1-8 UNC	0.6051	29,650	36,911	494.2	615.2	27,683
1-14 UNF	0.6791	33,276	41,425	554.6	690.4	31,069

*Torque figures based on assumption that excessive deformation of thread has not taken relationship between torque/tension out of its proportional range.

In actual practice, stud should not be used at its yield load. A factor of safety must be applied. It is generally recommended that studs not be used at more than 60% of yield strength, however, the factor of safety may vary up or down according to the particular application in which the studs are being used.

The user of these studs will make this determination.

	Ultimate Tensile	$L = SA$	Ultimate Torque	$T = 0.2 \times D \times L \div 12$
	Yield	$Z = YA$	Yield Torque	$T = 0.2 \times D \times Z \div 12$
Where	D =	Nominal Thread Diameter (in)	A =	Mean Effective Thread Area (META) (in ²)
	S =	Tensile Stress (psi)	Y =	Yield Stress (psi)
	L =	Tensile Load (lbs)	Z =	Yield Load (lbs)
	T =	Torque (ft-lbs)		

1 META is used instead of root area in calculating screw lengths because of closer correlation with actual tensile strength. META is based on mean diameter, which is the diameter of an imaginary co-axial cylinder whose surface would pass through the thread profile approximately midway between the minor and pitch diameters.

2 In actual practice, stud should not be used at its yield load. A factor of safety must be applied. It is generally recommended that studs not be used at more than 60% of yield strength, however, the factor of safety may vary up or down according to the particular application in which the studs are being used. **The user will make this safety factor determination.**

General Stud Specifications

Stainless Steel (As Formed) – 70,000 psi Minimum Ultimate, 35,000 psi Minimum Yield

Thread Diameter	META ¹ (sq. in.)	Yield Load ² (lbs.) at 35,000 psi	Ultimate Tensile Load (lbs) at 70,000 psi	Yield Torque ² (ft-lbs) at 35,000 psi	Ultimate Torque (ft-lbs) at 70,000 psi	Shear Strength (75% of Tensile Strength)
10-24 UNC	0.0174	609	1,218	1.9	3.9	914
10-32 UNF	0.0199	697	1,393	2.2	4.4	1,045
1/4-20 UNC	0.0317	1,110	2,219	4.6	9.2	1,664
1/4-28 UNF	0.0362	1,267	2,534	5.3	10.6	1,901
5/16-18 UNC	0.0522	1,827	3,654	9.5	19.0	2,741
5/16-24 UNF	0.0579	2,027	4,053	10.6	21.1	3,040
3/8-16 UNC	0.0773	2,706	5,411	16.9	33.8	4,058
3/8-24 UNF	0.0876	3,066	6,132	19.2	38.3	4,599
7/16- 14 UNC	0.1060	3,710	7,420	27.1	54.1	5,565
7/16-20 UNF	0.1185	4,148	8,295	30.2	60.5	6,221
1/2-13 UNC	0.1416	4,956	9,912	41.3	82.6	7,434
1/2-20 UNF	0.1597	5,590	11,179	46.6	93.2	8,384
5/8-11 UNC	0.2256	7,896	15,792	82.3	164.5	11,844
5/8-18 UNF	0.2555	8,943	17,885	93.2	186.3	13,414
3/4-10 INC	0.3340	11,690	23,380	146.1	292.3	17,535
3/4-16 UNF	0.3724	13,034	26,068	162.9	325.9	19,551
7/8-9 UNC	0.4612	16,142	32,284	235.4	470.8	24,213
7/8-14 UNF	0.5088	17,808	35,616	259.7	519.4	26,712
1-8 UNC	0.6051	21,179	42,357	353.0	706.0	31,768
1-14 UNF	0.6791	23,769	47,537	396.1	792.3	35,653

*Torque figures based on assumption that excessive deformation of thread has not taken relationship between torque/tension out of its proportional range.

In actual practice, stud should not be used at its yield load. A factor of safety must be applied. It is generally recommended that studs not be used at more than 60% of yield strength, however, the factor of safety may vary up or down according to the particular application in which the studs are being used.

The user of these studs will make this determination.

	Ultimate Tensile	$L = SA$	Ultimate Torque	$T = 0.2 \times D \times L \div 12$
	Yield	$Z = YA$	Yield Torque	$T = 0.2 \times D \times Z \div 12$
Where	D =	Nominal Thread Diameter (in)	A =	Mean Effective Thread Area (META) (in ²)
	S =	Tensile Stress (psi)	Y =	Yield Stress (psi)
	L =	Tensile Load (lbs)	Z =	Yield Load (lbs)
	T =	Torque (ft-lbs)		

1 META is used instead of root area in calculating screw lengths because of closer correlation with actual tensile strength. META is based on mean diameter, which is the diameter of an imaginary co-axial cylinder whose surface would pass through the thread profile approximately midway between the minor and pitch diameters.

2 In actual practice, stud should not be used at its yield load. A factor of safety must be applied. It is generally recommended that studs not be used at more than 60% of yield strength, however, the factor of safety may vary up or down according to the particular application in which the studs are being used. ***The user will make this safety factor determination.***

General Stud Specifications

High Strength Steel – 110,000[†] psi Minimum Ultimate, 92,000 psi Minimum Yield

Thread Diameter	META ¹ (sq. in.)	Yield Load ² (lbs.) at 92,000 psi	Ultimate Tensile Load (lbs) at 110,000 psi	Yield Torque ² (ft-lbs) at 92,000 psi	Shear Strength (75% of Tensile Strength)
M10 (0.394" dia.)	0.0899	8271	9889	54.3	7417
3/8-16	0.0773	7112	8503	44.3	6377
1/2-13	0.1417	13036	15587	108.6	11690

*Torque figures based on assumption that excessive deformation of thread has not taken relationship between torque/tension out of its proportional range.

[†]Dependent on diameter. Consult Nelson Stud Welding for additional information.

In actual practice, stud should not be used at its yield load. A factor of safety must be applied. It is generally recommended that studs not be used at more than 60% of yield strength, however, the factor of safety may vary up or down according to the particular application in which the studs are being used. **High Strength (HS) studs should not be welded to A36 structural steel.**

The user of these studs will make this determination.

	Ultimate Tensile	$L = SA$	Ultimate Torque	$T = 0.2 \times D \times L \div 12$
	Yield	$Z = YA$	Yield Torque	$T = 0.2 \times D \times Z \div 12$
Where	D =	Nominal Thread Diameter (in)	A =	Mean Effective Thread Area (META) (in ²)
	S =	Tensile Stress (psi)	Y =	Yield Stress (psi)
	L =	Tensile Load (lbs)	Z =	Yield Load (lbs)
	T =	Torque (ft-lbs)		

1 META is used instead of root area in calculating screw lengths because of closer correlation with actual tensile strength. META is based on mean diameter, which is the diameter of an imaginary co-axial cylinder whose surface would pass through the thread profile approximately midway between the minor and pitch diameters.

2 In actual practice, stud should not be used at its yield load. A factor of safety must be applied. It is generally recommended that studs not be used at more than 60% of yield strength, however, the factor of safety may vary up or down according to the particular application in which the studs are being used. **The user will make this safety factor determination.**

Stored Arc Welding Studs—Tensile/Yield Strengths

Mild Steel – 50,000 psi Ultimate, 35,000 psi Yield

Stainless Steel – 70,000 psi Ultimate, 35,000 psi Yield

Aluminum – 21,000 psi Ultimate, 20,000 psi Yield

Thread Diameter	META ¹ (sq. in.)	Ultimate Tensile Load (lbs)			Yield Load (lbs)		
		Mild Steel	Stainless Steel	Aluminum	Mild Steel	Stainless Steel	Aluminum
6-32 UNC	0.0090	450	630	189	315	315	180
8-32 UNC	0.0139	695	973	292	487	487	278
10-24 UNC	0.0174	870	1218	365	609	609	348
10-32 UNF	0.0199	995	1393	418	697	697	398
1/4-20 UNC	0.0317	1585	2219	666	1110	1110	634
5/16-18 UNC	0.0522	2610	3654	1096	1827	1827	1044

General Stud Specifications

Stud Dimensions

The length dimension, L, shown throughout the specification sheets, is the overall stud length before weld. The after weld in-place length will be shorter, depending on the size of the stud, the welding process, and weld settings. Approximate length reductions are shown in the table below.

Stud Diameter	Weld Process	Length Reduction
10 (0.134") and 12 gauge (0.105") TPC pins	Stored Arc	--
6-32 through 1/4-20, ATC, ATS, ATA, and FTC studs	Stored Arc	1/32"
10 gauge (0.134") P2P pins	Electric Arc	3/32"
3/16" through 1/2" diameter studs	Electric Arc	1/8"
5/8" through 7/8" diameter studs	Electric Arc	3/16"
1" diameter or larger studs	Electric Arc	1/4"
1/4" and 1/2" H4L Weld Through Metal Deck	Electric Arc	3/16" - 1/4"
5/8" H4L Weld Through Metal Deck	Electric Arc	5/16" - 3/8"
3/4" S3L Weld Through Metal Deck	Electric Arc	3/8" - 7/16"
M6 and 6mm diameter studs	Electric Arc	2mm
M8, 8mm, M10, 10mm, and M12 diameter studs	Electric Arc	3mm
12mm, M16, and 16mm diameter studs	Electric Arc	4mm
M20, 19mm, and 20mm diameter studs	Electric Arc	5mm
M24, 22mm, and 24mm diameter studs	Electric Arc	6mm

The stud length reduction is also often known as "burn-off."

The stud end configuration (chamfer, concentricity, and manufacturer's identification) of studs and pins will be selected at our option, depending on production requirements.

Threads

The standard external threads on studs are UNC-2A, and internal threads are UNC-2B, prior to plating. Other threads are available upon request. Standard thread length is 3". Longer thread lengths may be ordered. Whenever possible, threads are cold-rolled. The surface quality and strength of rolled threads is greatly improved compared to cut threads. The surface finish on rolled threads is less subject to wear and offers more corrosion resistance than cut threads.

Flux

Flux quality and quantity is an essential factor for obtaining consistent weld results. All standard stud weld Nelson studs 5/16" diameter and greater have a solid flux load. Rectangular studs 1/8" x 5/8" and less are not fluxed.

Plating

Plating is useful to increase a stud's corrosion resistance. Unless otherwise specified at the time of order, all Nelson studs will be supplied un-plated. Upon request, the following types of surface protection are available:

Zinc Plating – ASTM B-633

Copper Plating

Zinc Dichromating – ASTM B633 Fe/Zn 8

Nickel Plating

Zinc plating will adversely affect the weld quality. For this reason, the weld ends of stud weld studs are not plated.

Annealing

Nelson studs can be post annealed to a maximum of 75 Rockwell B hardness (HRB) for low carbon steel and 85 HRB for stainless steel. An extra charge is applicable for annealing and will be quoted if specified at the time of order.

Ferrules

For weld integrity, certain stud types must be welded using a ceramic ferrule. Appropriate ceramic ferrules are included in the stud purchase price. Ferrules will be shipped with studs, when required. Ferrules for welding special applications should be specified when orders for studs are placed.

General Stud Specifications

Accessories

Accessories depend on the stud type, diameter, length, and the ferrule being used, along with any specific fixturing or job conditions or restrictions. For accessory information, please refer to the stud, ferrule, and accessory specifications.

Weld Flash

When a stud is end-welded, weld metal forms around its base. The weld flash dimension is controlled by the design of the ferrule used. The diameter of the weld metal is generally larger than the diameter of the stud. Consideration is required in the design of mating parts that involve weld flash. Refer to the appropriate stud specification sheets for recommended weld flash clearance hole diameters.

Ordering

Each stud ordered from Nelson Stud Welding should be listed separately along with the appropriate ferrule. The stud style should be specified as well as the length, diameter, material, quantity, and any other information according to the stud specification sheet.

Your Nelson representative will be happy to advise you on the accessories required for welding the stud ordered, and is also available to aid in determining the proper stud for your application requirements.

Weight Charts for Shipping

Threaded Studs

Approximate Weight of Threaded Studs per 1000 (length before welding is used to determine weight) Weights are in pounds. To convert to kilograms, multiply values below by 0.4536

Stud Length	Diameter							
	$\frac{1}{4}$	$\frac{5}{16}$	$\frac{3}{8}$	$\frac{7}{16}$	$\frac{1}{2}$	$\frac{5}{8}$	$\frac{3}{4}$	$\frac{7}{8}$
$\frac{3}{4}$	8.3	12.8	18.8	25.5	34.5	--	--	--
1	11.0	17.0	25.0	34.0	46.0	70.0	--	--
1 $\frac{1}{4}$	13.8	21.3	31.3	42.5	57.5	87.5	133.8	--
1 $\frac{1}{2}$	16.5	25.5	37.5	51.0	69.0	105.0	160.5	243.8
1 $\frac{3}{4}$	19.3	29.8	43.8	59.5	80.5	122.5	187.3	284.4
2	22.0	34.0	50.0	68.0	92.0	140.0	214.0	325.0
2 $\frac{1}{4}$	24.8	38.3	56.3	76.5	103.5	157.5	240.8	365.6
2 $\frac{1}{2}$	27.5	42.5	62.5	85.0	115.0	175.0	267.5	406.3
2 $\frac{3}{4}$	30.3	46.8	68.8	93.5	126.5	192.5	294.3	446.9
3	33.0	51.0	75.0	102.0	138.0	210.0	312.0	487.5
3 $\frac{1}{4}$	35.8	55.3	81.3	110.5	149.5	227.5	347.8	528.1
3 $\frac{1}{2}$	38.5	59.5	87.5	119.0	161.0	245.0	374.5	568.8
3 $\frac{3}{4}$	41.3	63.8	93.8	127.5	172.5	262.0	401.3	609.4
4	44.0	68.0	100.0	136.0	184.0	280.0	428.0	650.0
4 $\frac{1}{4}$	46.8	72.3	106.3	144.5	195.5	297.5	454.8	690.6
4 $\frac{1}{2}$	49.5	76.5	112.5	153.0	207.0	315.0	481.5	731.3
4 $\frac{3}{4}$	52.3	80.8	118.8	161.5	218.5	332.5	508.3	771.9
5	55.0	85.0	125.0	170.0	230.0	350.0	535.0	812.0
Each Additional Inch	11.0	17.0	25.0	34.0	46.0	70.0	107.0	162.5
Add for Collar Studs	5.8	7.2	9.0	12.8	13.0	--	--	--
Ferrule	2.0	2.5	3.0	3.5	4.0	5.0	10.0	12.0

General Stud Specifications

Weight Charts for Shipping

Unthreaded Studs

Approximate Weight of Threaded Studs per 1000 (length before welding is used to determine weight) Weights are in pounds. To convert to kilograms, multiply values below by 0.4536

Length	Diameter								
	$\frac{3}{16}$	$\frac{1}{4}$	$\frac{5}{16}$	$\frac{3}{8}$	$\frac{7}{16}$	$\frac{1}{2}$	$\frac{5}{8}$	$\frac{3}{4}$	$\frac{7}{8}$
$\frac{3}{4}$	6.0	10.5	16.4	23.5	31.9	41.7	--	--	--
1	8.0	14.0	21.8	31.3	42.5	55.6	86.6	--	--
1 $\frac{1}{4}$	10.0	17.5	27.3	39.1	53.1	69.5	108.3	156.0	--
1 $\frac{1}{2}$	12.0	21.0	32.7	47.0	63.8	83.4	129.9	187.2	255.0
1 $\frac{3}{4}$	14.0	24.5	38.2	54.8	74.4	97.3	151.6	218.4	297.5
2	16.0	28.0	43.6	62.6	85.0	111.2	173.2	249.6	340.0
2 $\frac{1}{4}$	18.0	31.5	49.1	70.4	95.6	125.1	194.9	280.8	382.5
2 $\frac{1}{2}$	20.0	35.0	54.5	78.3	106.3	139.0	216.5	312.0	425.0
2 $\frac{3}{4}$	22.0	38.5	60.0	86.1	116.9	152.9	238.2	343.2	467.5
3	24.0	42.0	65.4	93.9	127.5	166.8	259.8	374.4	510.0
3 $\frac{1}{4}$	26.0	45.5	70.9	101.7	138.1	180.7	281.5	405.6	552.5
3 $\frac{1}{2}$	28.0	49.0	76.3	117.4	148.8	194.6	303.1	436.8	595.0
3 $\frac{3}{4}$	30.0	52.5	81.8	125.2	159.4	208.5	324.8	468.0	637.5
4	32.0	56.0	87.2	125.2	170.0	222.4	346.4	499.2	680.0
4 $\frac{1}{4}$	34.0	59.5	92.7	133.0	180.6	236.3	368.1	530.4	722.5
4 $\frac{1}{2}$	36.0	63.0	98.1	140.9	191.3	250.2	389.7	561.6	765.0
4 $\frac{3}{4}$	38.0	66.5	103.6	148.7	210.9	264.1	411.4	592.8	807.5
5	40.0	70.0	109.0	156.5	212.5	278.0	433.0	624.0	850.0
Each Additional Inch	8.0	14.0	21.8	31.3	42.5	55.6	86.6	124.8	170.0
Ferrule	3.0	3.5	4.0	5.0	6.0	7.5	9.0	27.0	37.0

General Stud Specifications

Weight Charts for Shipping

Shear Connectors

Approximate Weight of Threaded Studs per 1000 (length before welding is used to determine weight) Weights are in pounds. To convert to kilograms, multiply values below by 0.4536

S3L Shear Connector Description	Small Shear Cartons				
	Weight Per Box, w/o Box	Quantity Per Box	Quantity Per Pallet	Weight Per 1000 Pieces	Net Weight of Pallet
3/4 x 3 3/16	60.9	130	3,510	468	1,643
3/4 x 3 3/8	58.9	120	3,240	488	1,589
3/4 x 3 7/8	60.2	110	2,970	548	1,625
3/4 x 4 3/16	55.5	95	2,565	585	1,499
3/4 x 4 7/8	54.3	80	2,160	678	1,466
3/4 x 5 3/16	56.6	80	2,160	708	1,529
3/4 x 5 3/8	56.3	75	2,025	750	1,519
3/4 x 5 7/8	56.6	70	1,890	794	1,529
3/4 x 6 3/16	49.8	60	1,620	825	1,345
3/4 x 7 3/16	51.9	55	1,485	946	1,403
3/4 x 8 3/16	42.9	40	1,080	1,067	1,158
7/8 x 3 11/16	61.3	85	2,295	726	1,656
7/8 x 4 3/16	60.0	75	2,025	811	1,642
7/8 x 5 3/16	58.2	60	1,620	980	1,584
7/8 x 6 3/16	56.6	50	1,350	1,153	1,528
7/8 x 7 3/16	52.0	40	1,080	1,320	1,426
7/8 x 8 3/16	49.9	35	945	1,473	1,391

Headed Anchors

Approximate Weight of Threaded Studs per 1000 (length before welding is used to determine weight) Weights are in pounds. To convert to kilograms, multiply values below by 0.4536

H4L Headed Anchor Description	Small Shear Cartons				
	Weight Per Box w/o Box	Quantity Per Box	Quantity Per Pallet	Weight Per 1000 Pieces	Net Weight of Pallet
1/4 x 2 11/16	44.0	1000	27,000	44	1,188
1/4 x 4 1/8	36.0	550	14,850	65	965
3/8 x 4 1/8	58.0	375	10,125	155	1,569
3/8 x 6 1/8	29.7	140	3,780	212	802
1/2 x 2 1/8	67.0	400	10,800	170	1,836
1/2 x 3 1/8	60.0	275	7,425	226	1,678
1/2 x 4 1/8	50.0	180	4,860	282	1,370
1/2 x 5 5/16	41.0	120	3,240	341	1,107
1/2 x 6 1/8	40.1	105	2,835	393	1,114
1/2 x 8 1/8	33.0	65	1,755	504	885
5/8 x 2 11/16	61.0	195	5,265	315	1,658
5/8 x 4 3/16	55.0	125	3,375	450	1,518
5/8 x 6 9/16	45.0	70	1,890	652	1,232
5/8 x 8 3/16	40.0	50	1,350	793	1,070

General Stud Specifications

Weight Charts for Shipping

Weights listed in tables do not include weight of box.

Empty shear carton: 1.00 lb. each Pallet size: 36" x 36"

Shear cartons: 27 per pallet Approximate volume of pallet: 18 cu. ft. (0.51 cu. meter)

NOTE: All dimensions have been calculated at the mean dimensions of the tolerance allowance, and will vary if the product is at a minimum or maximum of tolerance.

Insulation Fastener Quantities

Insulation Pin Type	Quantity Per Carton
10 ga. P2P less than 2-1/2"	5,000
10 ga. P2P 3" long	4,000
10 ga. P2P 3-1/2" through 6" long	2,000
12 ga. CHP with 1-3/16" dia. head, all lengths	1,000
10 ga. CHP with 1-1/2" dia. head, all lengths	1,000
10 ga. CHP with 1-1/2" dia. head, 2" through 3"	500

Insulation Pin Type	Quantity Per Carton
10 ga. and 12 ga. TPC less than 2-1/2"	5,000
10 ga. and 12 ga. TPC 2-1/2" through 6"	2,500
1" x 1-1/4" Rectangular Speed Clip	5,000
1-1/2" Square Speed Clip	3,000
1-1/2" Round Speed Clip	5,000
2-1/2" Square Speed Clip	1,000
2" Round Speed Clip	1,000

Deliveries

Delivery on stock items will be made within three (3) days following the date of order receipt. Non-stock items or special items, which require manufacture, will be acknowledged in writing with a delivery promise.

Extra Charges

Stock items are not subject to additional charges.

With approval from Nelson, a non-stock item may be given production priority if required before the acknowledged delivery date. Should such a service be required and approved, the customer will be charged an extra "break-in" fee.

A non-stock or special stud that requires manufacturing may be subject to a set-up charge for setting dies onto the machines and changing production processes.

Studs

Externally Threaded

NELSON STUD WELDING SPECIFICATION

B5L 90° Bent Collar Studs

B5L bent collar studs are used in shipbuilding to mount electrical cable supports to angle or bar downcomers from the ceiling or overhead of ships. They are normally used to attach a cross bar between a pair of downcomers.

Nelson bent collar studs are used in industrial applications to retain cables or hoses using clips. The thread extension speeds assembly over installing a bolt into an internal threaded boss or tapped stud.

A special chuck and foot plate are needed to hold the bent stud and ferrule during the stud welding process.

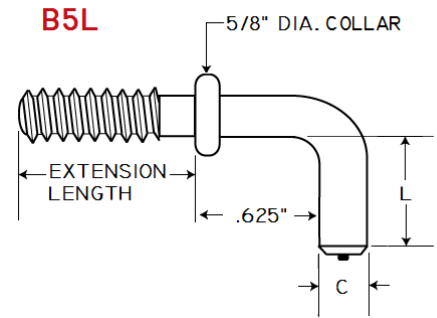

When ordering, specify: Type, Base Diameter, Base Length, Thread Size, Extension Length, Material, Quantity, and Part Number

Example: B5L 0.330 x 1-5/8"; 3/8-16 x 1-3/8"; Mild Steel; 5,000 pieces; #101006009

Base ¹ C	Minimum Base Length L	Thread Size	Thread Length	Minimum Extension Length	Required Standard Accessories		
					Ferrule	Ferrule Foot Plate	Chuck
0.330	0.625	3/8-16	9/16 – 5/8	0.750	100101083	501006007	500009010

¹Special bent collar studs are available with full 0.375" diameter weld bases.

MATERIALS: Studs are available in Low Carbon Mild Steel and 18-8 Stainless Steel. For specific grade information, physical and chemical properties, and conforming standards, please see [General Material Specifications](#).

THREADS: Standard external threads are UNC-2A.

FLUX: All Nelson B5L studs have a solid flux load.

Studs

Externally Threaded

NELSON STUD WELDING SPECIFICATION

CFL Fully Threaded Studs

Nelson CFL studs are recommended for fastening applications where threads are needed for the full fastener length. CFL studs are available in thread diameters of 1/4"-20 through 1"-8. Nelson fully threaded studs have a short length of pitch diameter weld base. This length is melted off during the stud welding process so that usable thread extends down to the top of the weld flash on installed studs. For similar function studs, see [CFP Small Diameter Threaded studs](#), [CJL Reduced Base studs](#), [CPL Partially Threaded Studs](#), [HBA Aluminum Full Base Diameter Threaded studs](#), [HBL Full Base Diameter Threaded Studs](#), [Banding Cable Hangers](#), [CrimpLok™ Cable Hangers](#), and [Watertight nuts](#).

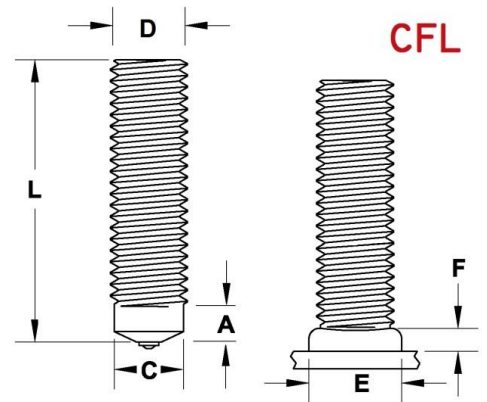

When ordering, specify: Type, Diameter, Before Weld Length, Material, Quantity, and Part Number

Example: CFL 3/8-16 x 2-1/4"; Mild Steel; 10,000 pieces; #101017193

Thread Size D	Minimum Stud Length L	Burn Off	Weld Base Diameter	Weld Base Length	Weld Flash Size		Flash Clearance	Required Standard Accessories			
			C	A	E	F		Ferrule	Grip	Chuck	Foot
1/4-20	0.780	0.125	0.215	0.142	0.359	0.109	0.437	100101067	501001007	500001007	502001137
5/16-18	0.780	0.125	0.275	0.142	0.437	0.109	0.500	100101024	501001006	500001009	502001137
3/8-16	0.812	0.125	0.330	0.190	0.500	0.125	0.562	100101025	501001007	500001011	502001137
7/16-14	0.812	0.125	0.389	0.205	0.562	0.125	0.625	100101026	501001008	500001012	502001137
1/2-13	0.875	0.125	0.448	0.221	0.625	0.156	0.680	100101027	501001009	500001014	502001137
9/16-12	1.062	0.187	0.503	0.221	0.750	0.156	0.813	100101011	501001011	500001015	502001138
5/8-11	1.000	0.187	0.562	0.284	0.781	0.187	0.843	100101028	501001011	500001016	502001138
3/4-10	1.250	0.187	0.680	0.346	0.937	0.250	1.031	100101029	501001014	500001018	502001002
7/8-9	1.500	0.187	0.798	0.377	1.125	0.312	1.250	100101140	501001015	500001019	502001003
1-8	1.500	0.250	0.913	0.500	1.375	0.375	1.437	100101045	501001016	500001085	502001003

Stud lengths shorter than those shown above can be supplied in sizes 1/4"-20 through 1/2"-13 by using special low profile ceramic ferrules. All low profile ferrules, except the 1/4"-20 ferrule, were designed for use with full diameter weld base studs. For this reason, the weld flash size and flash clearance are increased. The minimum length, recommended weld flash clearance, ferrules, and ferrule grip numbers are shown below.

Thread Size	Minimum Stud Length	Weld Flash Size		Flash Clearance	Required Accessories For Short Studs			
		E	F		Ferrule	Grip	Chuck	Foot
1/4-20	0.640	0.359	0.109	0.437	100101077	501001005	500001007	502001137
5/16-18	0.640	0.437	0.109	0.500	100101030	501001007	500001009	502001137
3/8-16	0.687	0.500	0.125	0.593	100101031	501001008	500001011	502001137
7/16-14	0.687	0.593	0.140	0.656	100101032	501001009	500001012	502001137
1/2-13	0.750	0.687	0.156	0.750	100101033	501001001	500001014	502001138

MATERIALS: Studs are available in Low Carbon Mild Steel and Stainless Steel. For specific grade information, physical and chemical properties, conforming standards, and information on stud plating, please see [General Material Specifications](#). Other alloys can be special ordered.

THREADS: Standard CFL studs are available with up to 3" of thread length in UNC-2A coarse thread. Other thread pitch series, and thread lengths greater than 3" are available as special order.

FLUX: All Nelson fully threaded CFL studs have a solid flux load.

Studs

Externally Threaded

NELSON STUD WELDING SPECIFICATION

CPL Partially Threaded Studs

Nelson CPL studs are recommended for fastening applications to heavy gauge base materials where development of the full fastener strength is needed. The unthreaded section minimizes the weld flash diameter and height. It also reduces the possibility of stud hang up in the ferrule cavity if gun parts are slightly misaligned.

Nelson partially threaded studs have a pitch diameter weld base and are available in thread diameters of 1/4"-20 through 1"-8 with unlimited length.

For similar function studs, see Nelson [CFL Full Threaded studs](#), [CFP Small Diameter Threaded studs](#), [CJL Reduced Base studs](#), [HBL Full Base Diameter Threaded studs](#), [B5L 90° Bent Collar studs](#), [Banding Cable Hangers](#), [CrimpLok™ Cable Hangers](#), and [Watertight nuts](#).

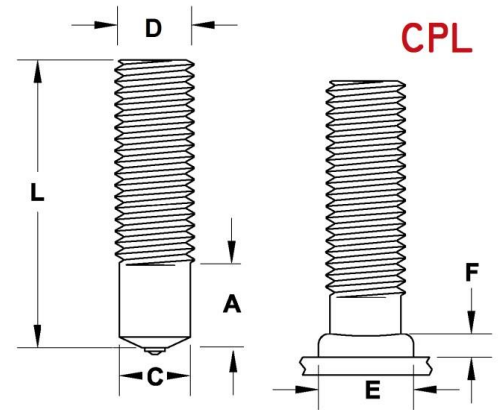

When ordering, specify: Type, Diameter, Before Weld Length, Material, Quantity, and Part Number

Example: CPL 3/8-16 x 2-1/4"; Mild Steel; 10,000 pieces; #101017193

Thread Size D	Minimum Stud Length L	Burn Off	Weld Base Diameter C	Weld Base Length A	Weld Flash Size		Flash Clearance	Required Standard Accessories			
					E	F		Ferrule	Grip	Chuck	Foot
1/4-20	0.562	0.125	0.215	0.375	0.312	0.093	0.375	100101034	501001005	500001007	502001137
5/16-18	0.593	0.125	0.275	0.375	0.406	0.109	0.469	100101035	501001006	500001009	502001137
3/8-16	0.625	0.125	0.330	0.385	0.468	0.109	0.531	100101036	501001007	500001011	502001137
7/16-14	0.718	0.125	0.389	0.438	0.531	0.125	0.594	100101037	501001008	500001012	502001137
1/2-13	0.843	0.125	0.448	0.500	0.593	0.156	0.656	100101038	501001009	500001014	502001137
9/16-12	0.875	0.187	0.503	0.531	0.671	0.171	0.734	100101117	501001010	500001015	502001138
5/8-11	1.000	0.187	0.562	0.625	0.750	0.187	0.812	100101039	501001011	500001016	502001138
3/4-10	1.250	0.187	0.680	0.791	0.921	0.250	0.984	100101040	501001014	500001018	502001002
7/8-9	1.375	0.187	0.798	0.858	1.046	0.312	1.125	100101041	501001015	500001019	502001003
1-8	1.500	0.250	0.913	0.926	1.187	0.375	1.250	100101042	501001016	500001085	502001003

MATERIALS: Studs are available in Low Carbon Mild Steel and Stainless Steel. For specific grade information, physical and chemical properties, conforming standards, and information on stud plating, please see [General Material Specifications](#). Other alloys can be special ordered.

THREADS: Standard CPL studs are available with up to 3" of thread length in UNC-2A coarse thread. Other thread pitch series, and thread lengths greater than 3" are available as special order.

FLUX: All Nelson partially threaded CPL studs have a solid flux load.

Studs

Externally Threaded

NELSON STUD WELDING SPECIFICATION

CFP, CPP, FFP, FPP Small Diameter Threaded Studs

These Nelson threaded stud welding studs, which are less than 1/4" in diameter, are supplied with ceramic ferrules but without the flux loads used in larger diameter studs.

The first letter in the stud type designates the thread series: "C" for coarse threaded studs, "F" for fine threaded studs. The second letter describes the length of the thread or the weld base diameter: "P" for a pitch diameter weld, and "F" for a fully threaded stud. After welding a fully threaded stud, the threads will start at the top of the weld flash. The last letter, "P" indicates that the stud has a pointed weld end as opposed to the flux-loaded weld ends used on larger diameter studs. Flux loaded studs are designated by the letter "L".

For similar function studs, see Nelson [CFL Full Threaded studs](#), [CJL Reduced Base studs](#), [CPL Partially Threaded studs](#), [HBA Aluminum Full Base Threaded Studs](#), and [HBL Full Base Diameter Threaded studs](#).

CFP, CPP, FFP, FPP

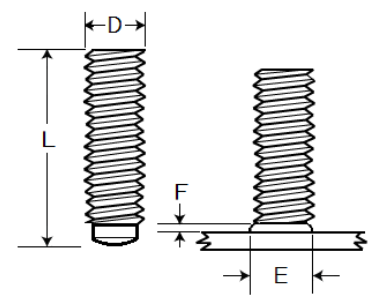

When ordering, specify: Type, Description, Thread Size, Length, Material, Quantity, and Part Number

Example: CFP #10-24 x 1-1/4"; Mild Steel; 10,000 pieces; #101010492

Thread Size D	Major Diameter D	Burn Off	Minimum Length	Weld Flash Size		Weld Flash Clearance	Ferrule	Required Standard Accessories		
			L	E	F			Chuck	Ferrule Grip	Foot Assembly
#6-32	0.132	0.062	0.625	0.218	0.093	0.265	10010100	50000100	50100100	50200113
#8-32	0.164	0.062	0.625	0.234	0.093	0.281	10010100	50000100	50100100	50200113
#10-24	0.187	0.062	0.625	0.281	0.093	0.328	10010100	50000100	50100100	50200113
#10-32	0.187	0.062	0.625	0.281	0.093	0.328	10010100	50000100	50100100	50200113

MATERIALS: Studs are available in Low Carbon Mild Steel and 18-8 Stainless Steel. For specific grade information and physical and chemical properties, and conforming standards, please see [General Material Specifications](#).

THREADS: Standard external threads are UNC-2A, or UNF-2A for #10-32.

Studs

Externally Threaded

NELSON STUD WELDING SPECIFICATION

HBL Full Base Diameter Threaded Studs

Nelson HBL stud are available in thread sizes from #10-24 through 1"-8. The full diameter weld base gives a larger cross-sectional area through the weld zone than on the CPL pitch diameter studs. The increased area is desirable with special stud alloys or when studs are to be welded to specialty base materials.

The HBL studs are more costly than the CPL pitch diameter studs due to the manufacturing steps and material costs involved during manufacturing.

CPL or CFL studs are generally preferred over the HBL studs unless there are technical reasons that specify the need for full base HBL Studs

For similar function studs, see Nelson [CFL Fully Threaded studs](#), [CFP Small Diameter Threaded studs](#), [CJL Reduced Base studs](#), [CPL Partially Threaded Studs](#), [CrimpLok™ Cable Hangers](#), [HBA Aluminum Full Base Diameter Threaded studs](#), and [J2L "J" Bolt studs](#).

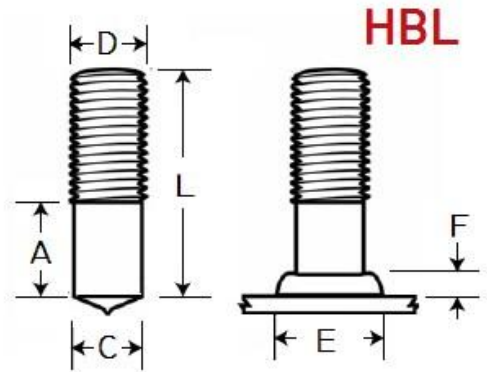

When ordering, specify: Type, Diameter, Before Weld Length, Material, Quantity, and Part Number

Example: HBL 3/8-16 x 2-5/8"; Mild Steel; 10,000 pieces; #101045812

Thread Size	Weld Base Diameter	Minimum Unthreaded Length	Minimum Stud Length	Burn Off	Weld Flash Size		Flash Clearance	Required Standard Accessories		
					E	F		Ferrule	Grip	Chuck
D	C	A	L							
#10-24	0.188	0.187	0.780	0.093	0.281	0.093	0.328	100101003	501001004	500001005
1/4-20	0.250	0.187	0.780	0.125	0.359	0.109	0.437	100101067	501001007	500001007
5/16-18	0.312	0.250	0.780	0.125	0.437	0.109	0.500	100101007	501001006	500001009
3/8-16	0.375	0.265	0.813	0.125	0.500	0.125	0.593	100101099	501001009	500001011
7/16-14	0.438	0.281	0.813	0.125	0.593	0.140	0.656	100101009	501001008	500001012
1/2-13	0.500	0.296	0.968	0.187	0.687	0.156	0.750	100101114	501001011	500001014
5/8-11	0.625	0.359	1.000	0.187	0.875	0.187	0.937	100101187	501001014	500001016
1/4-10	0.750	0.500	1.250	0.187	1.062	0.250	1.125	100101152	501001014	500001018
7/8-9	0.875	0.625	1.500	0.187	1.125	0.312	1.250	100101140	501001015	500001019
1-8	1.000	0.750	1.647	0.250	1.375	0.375	1.437	100101045	501001016	500001085
1-1/8-7	1.125	1.000	2.000	0.250	1.500	0.375	1.625	100101143	501001017	500001113

MATERIALS: Studs are available in Low Carbon Mild Steel and 18-8 Stainless Steel. Other materials are available by special order. For specific grade information and physical and chemical properties, conforming standards, and information on stud plating, please see [General Material Specifications](#).

THREADS: Standard threads are available up to 3" in length with UNC-2A coarse thread pitch.

FLUX: All Nelson full base diameter threaded studs have a solid flux load

Studs

Externally Threaded

NELSON STUD WELDING SPECIFICATION

CKL Collar Studs

CKL collar studs are used to mount circuit boards and panels where a stand-off is desired. They are also used to retain cables or hoses using a clip. The thread extension speeds assembly over installing a bolt into an internal threaded boss or tapped stud.

The ferrules supplied with CKL studs have gripping neck diameters larger than the collar diameter, G. This allows the gun to strip straight off the welded studs.

For similar function, see Nelson [BSL 90° Bent Collar Studs](#), [Banding Cable Hangers](#), [CKA Aluminum Collar studs](#), [CrimpLok™ Cable Hangers](#), [Grounding studs](#), [SBA Aluminum Shoulder Stud](#), and [SBL Shoulder Studs](#).

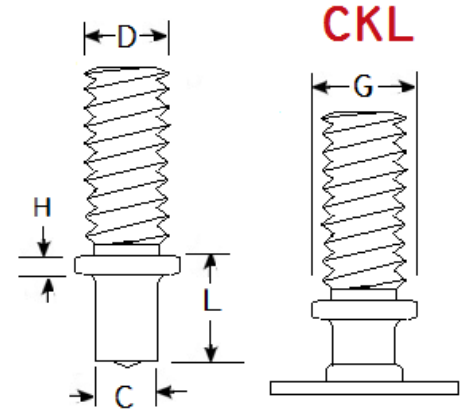

When ordering, specify: Type, Base, Diameter, Base Length, Thread Size, Thread Length, Material, Quantity, and Part Number

Example: CKL 0.330 x 1.125", 3/8-16 x 0.750"; Mild Steel; 10,000 pieces; #101015077

Thread Size D	Base C	Minimum Base	Collar		Required Standard Accessories			
		L	G	H	Ferrule	Chuck	Ferrule Grip ¹	Foot ¹
1/4-20	0.215	0.500	0.500	0.093	100101066	500001007	501001011	502001138
5/16-18	0.275	0.500	0.562	0.093	100101073	500001009	501001011	502001138
3/8-16	0.330	0.500	0.625	0.093	100101083	500001011	501001011	502001138
1/2-13	0.448	0.500	0.750	0.093	100101118	500001014	501001012	502001138

For dimensions of the weld flash, refer to [CPL studs](#)

Thread Size D	Ferrule	Neck Dia.	Foot Plate ¹
1/4-20	100101066	0.785	501006007
5/16-18	100101073	0.785	501006007
3/8-16	100101083	0.785	501006007
1/2-13	100101118	0.921	501006011

¹Ferrule footplates can be used in place of ferrule grips and feet when welding CKL studs.

MATERIALS: Studs are available in Low Carbon Mild Steel and 18-8 Stainless Steel. Other materials are available by special order. For specific grade information and physical and chemical properties, and conforming standards, please see [General Material Specifications](#).

THREADS: Standard threads are UNC-2A coarse thread prior to any plating, 3" maximum length. Other threads, and thread lengths greater than 3" are available as special order.

FLUX: All Nelson CKL studs have a solid flux load.

Studs

Externally Threaded

NELSON STUD WELDING SPECIFICATION

SBL and VBL Shoulder Studs

Nelson SBL and VBL shoulder studs have weld base diameters that are larger than the diameter of the threaded extensions. They are available with weld base diameters of 1/4" through 1" and threaded extension sizes up to 7/8-9 or 7/8-14.

The Nelson shoulder studs are used as mountings for panels and hardware where a standoff shoulder is needed. SBL studs are similar to CKL collar studs, but the larger weld base provides improved bend resistance.

Both chuck size and part numbers are determined by the thread size, C. Please refer to the [Nelson CPL stud specification sheet](#) to find the appropriate chuck for the thread size and part number.

Shoulder studs are also made with fine threads on the extension above the base. Shoulder studs with fine studs are called VBL Shoulder Studs.

Similar function studs are [CKL Collar studs](#) and [TBL internally tapped studs](#).

When ordering, specify: Type, Base Diameter, Base Length, Extension Thread Size, Extension Length, Material, Quantity, and Part Number

Example: SBL 1/2 x 1-1/8; 1/4-20 x 4-1/2"; Mild Steel; 10,000 pieces; #101093282

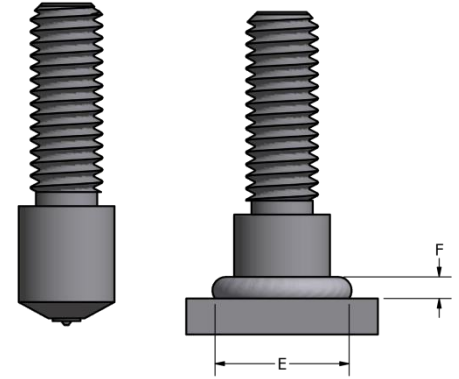

Major Diameter D	Maximum Thread Diameter C	Minimum Length A	Minimum Length Unplated Studs L	Minimum Length Zinc Plated Studs L	Weld Flash		Required Standard Accessories		
					E	F	Ferrule	Grip	Foot
0.250	#8-32	0.187	0.312	0.500	0.359	0.109	100101067	501001007	500001007
0.312	#10-24	0.250	0.312	0.500	0.437	0.109	100101007	501001006	500001009
0.375	1/4-20	0.250	0.312	0.500	0.500	0.125	100101099	501001009	500001011
0.437	5/16-18	0.312	0.343	0.562	0.593	0.140	100101009	501001008	500001012
0.500	3/8-16	0.375	0.375	0.562	0.687	0.156	100101114	501001011	500001014
0.625	1/2-13	0.500	0.500	0.625	0.875	0.187	100101187	501001014	500001102
0.750	5/8-11	0.562	0.625	0.750	1.062	0.250	100101125	501001014	500001018
0.875	3/4-10	0.625	0.625	0.750	1.125	0.312	100101140	501001015	500001019
1.000	7/8-9	0.750	0.687	0.750	1.375	0.375	100101045	501001016	500001085

MATERIALS: Studs are available in Low Carbon Mild Steel and 18-8 Stainless Steel. Material selection is dependent on anticipated service temperature range. For specific grade information and physical and chemical properties, conforming standards, and information on stud plating, please see [General Material Specifications](#).

THREADS: The external threads on SBL studs are UNC-2A. The external threads on VBL studs are UNF-2A.

FLUX: All Nelson SBL and VBL studs have a solid flux load.

Studs

Externally Threaded

NELSON STUD WELDING SPECIFICATION

CJL Reduced Base Studs

CJL threaded studs have a reduced weld base diameter, C, to produce a smaller weld flash diameter than when Nelson CPL studs weld base are used. The smaller weld flash allows the use of smaller clearance holes.

The strength of the assembly is determined by the area of the reduced weld base rather than the thread area.

For similar function studs, see [Nelson CFL Fully Threaded studs](#), [CFP Small Diameter Threaded Studs](#), [CPL Partially Threaded studs](#), [HBA Full Base Diameter Aluminum studs](#), and [HBL Full Base Diameter studs](#).

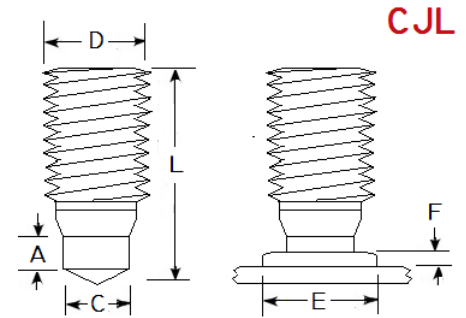

When ordering, specify: Type, Diameter, Before Weld Length, Material, Quantity, and Part Number
Example: CJL 1/2-13 x 2-1/4"; Stainless Steel; 10,000 pieces; #10101408

Thread Size	Minimum Length L	Weld Base Diameter C	Weld Base Length A	Weld Flash Dimensions			Burn Off	Required Standard Accessories			
				Diameter E	Height F	Clearance Diameter		Ferrule	Ferrule Grip	Chuck	Foot
1/4-20	0.827	0.187	0.187	0.281	0.093	0.328	0.093	100101016	501001005	500001007	502001137
5/16-18	0.827	0.218	0.203	0.343	0.093	0.390	0.093	100101017	501001006	500001009	502001137
3/8-16	0.827	0.275	0.218	0.437	0.109	0.469	0.125	100101018	501001007	500001011	502001137
7/16-14	0.922	0.343	0.250	0.531	0.125	0.546	0.125	100101019	501001008	500001012	502001137
1/2-13	0.922	0.390	0.281	0.548	0.140	0.609	0.125	100101020	501001009	500001014	502001137
5/8-11	0.968	0.500	0.312	0.656	0.156	0.718	0.156	100101021	501001011	500001016	502001138
3/4-10	1.172	0.625	0.343	0.813	0.187	0.875	0.187	100101022	501001014	500001018	502001002

MATERIALS: Studs are available in Low Carbon Mild Steel and Stainless Steel. Other materials are available by special order. For specific grade information and physical and chemical properties, conforming standards, and information on stud plating, please see [General Material Specifications](#).

THREADS: Standard threads are UNC-2A coarse thread prior to any plating, 3" maximum length. Other threads, and thread lengths greater than 3" are available as special order.

FLUX: All Nelson CJL studs have a solid flux load.

Studs

Externally Threaded

NELSON STUD WELDING SPECIFICATION

Watertight Nuts

Nelson 1/2-13 watertight nuts are used to attach wood decking to the railroad car floors or aircraft carrier decks. They are installed on standard Nelson CPL threaded studs. The CPL studs can be welded through pre-drilled holes in the wood by using ferrule tubing and long style chucks.

It is this application that prompted Ted Nelson to develop the stud welding process in 1939. His solution of stud welding through holes in wood, plastic, or other materials to steel base plate is still the quickest and most effective method of fabricating a variety of assemblies.

Nelson Watertight nuts are available with or without or zinc plated steel. They can be supplied with normal or locking threads. This self-locking feature is desirable on wood, which may expand and contract with changes in temperature or exposure to moisture. Railroad cars are also subject to severe vibration, which may loosen nuts, thus making the locking threads capability desirable in this application

These nuts can also be used to install thick UHMW plastic sheets.

In addition to Nelson watertight nuts, specialty nuts can also be supplied for use on 1/4-20, 3/8-16, and 1/2-13 threaded studs. Drive tool #518015000 is necessary for the installation of Watertight Nuts

For similar function studs, see Nelson [CPL Partially Threaded studs](#) and [CFL Fully](#)

When ordering, specify: Thread Size, Description, Locking, Plating, Quantity, and Part Number

Example: 1/2-13 Watertight Nut with self-locking threads; unthreaded; Mild Steel; 10,000 pieces; #101302244

Part Description	Plating	Part Number
1/2-13 Watertight nut with self-locking	Yes	101302274
1/2-13 Watertight nut with self-locking	No	101302244
1/2-13 Watertight nut with non-locking	Yes	101302256
1/2-13 Watertight nut with non-locking	No	101302243

MATERIALS: Watertight Nuts are available only in Mild Steel. For specific grade information and physical and chemical properties, conforming standards, and information on plating and heat treating, please see [General Material Specifications](#).

PLATING: Watertight Nuts can be electrozinc plated to ASTM B633, Fe/Zn 8.

THREADS: Standard internal threads are UNC-2B.

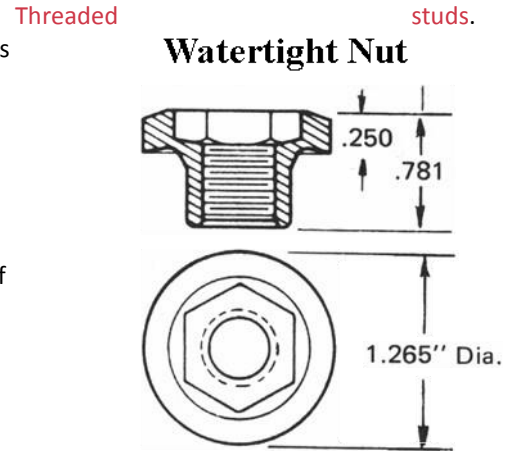

Studs

Internally Threaded

NELSON STUD WELDING SPECIFICATION

TBL and PBL Internally Threaded Studs

Nelson’s internally threaded TBL and PBL studs are intended to be used on heavy base materials and serve as a means of attaching or anchoring components to a structure. When maximizing the stud diameter to tap ratio, the stud can also serve as a standoff post.

Standard TBL studs have internal UNC-2B coarse series threads. Internally tapped studs can also be supplied with UNF-2B fine threads. Studs with fine threads are called PBL studs, rather than TBL studs.

The “S” dimension is predicated on stud diameter, not tap size. Secondary bottom tapping or flat bottom drilling is available as a special order with significant price additions.

Reduced base studs are available but depth of tap drill point should not pass below shoulder of reduced diameter shoulder so that stud strength is not compromised.

For similar function studs, see Nelson [CKL Collar studs](#), [NBL Unthreaded studs](#), [S6L Sprinkler studs](#), [SBL Shoulder studs](#), and [Metric TBL Internally Threaded Studs](#).

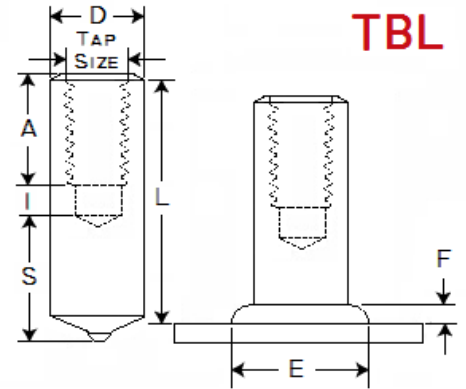

When ordering, specify: Type, Diameter, Before Weld Length, Tap Size, Material, Quantity, and Part Number

Example 1: TBL 1/2 x 1-1/8", with 3/8-16 x 5/8" Deep Tap; Mild Steel; 10,000 pieces; #101102731

Example 2: PBL 1/2 x 1", with 5/16-24 x 1/2" Deep Tap; Mild Steel; 10,000 pieces; #101079024

Stud Diameter	Maximum Tap Size	Minimum Values				Burn Off	Weld Flash		Flash Clearance	Required Standard Accessories			
	C	D	A	I	S		E	F		Ferrule	Grip	Chuck	Foot
1/4	#8-32	0.250	0.250	0.125	0.125	0.125	0.359	0.109	0.437	100101067	501001007	500001007	502001137
5/16	#10-24	0.312	0.281	0.156	0.140	0.125	0.437	0.109	0.500	100101007	501001006	500001009	502001137
3/8	1/4-20	0.375	0.375	0.203	0.140	0.125	0.500	0.125	0.593	100101099	501001009	500001011	502001137
7/16	5/16-18	0.437	0.468	0.234	0.156	0.125	0.596	0.140	0.656	100101009	501001008	500001012	502001137
1/2	3/8-16	0.500	0.562	0.265	0.156	0.125	0.687	0.156	0.750	100101114	501001011	500001014	502001137
9/16	7/16-14	0.562	0.656	0.296	0.187	0.156	0.750	0.187	0.812	100101039	501001011	500001015	502001137
5/8	1/2-13	0.625	0.750	0.319	0.218	0.187	0.921	0.187	0.937	100101187	501001014	500001016	502001137
11/16	9/16-12	0.687	0.843	0.358	0.250	0.187	1.062	0.250	0.984	100101040	501001014	500001098	502001137
3/4	5/8-11	0.750	0.937	0.406	0.250	0.187	1.062	0.250	1.125	100101152	501001014	500001018	502001002
7/8	3/4-10	0.875	1.125	0.453	0.281	0.187	1.125	0.312	1.250	100101140	501001015	500001019	502001002
1	7/8-9	1.000	1.312	0.531	0.312	0.250	1.375	0.375	1.437	100101045	501001016	500001085	502001002

In the table above, F represents the height of the weld flash; I, the imperfect thread depth; and S, the depth of the solid weld base.

MATERIALS: TBL and PBL studs are available in Low Carbon Mild Steel and 18-8 Stainless Steel. For specific grade information and physical and chemical properties, conforming standards, and information on stud plating and heat treating, please see [General Material Specifications](#).

THREADS: TBL studs have internal UNC-2B coarse threads. PBL studs have internal UNF-2B fine threads.

FLUX: All standard Nelson internally threaded studs have a solid flux load.

Studs

Internally Threaded

NELSON STUD WELDING SPECIFICATION

S6L Sprinkler Studs

S6L Studs are internally threaded studs with a reduced weld base. They are named for their primary application, which is the attachment of hangers to hold piping for overhead sprinkler systems.

Nelson S6L studs are not solely used for sprinkler systems, and are applicable to many other mounting applications.

For a similar function stud, see Nelson [TBL Internally Threaded studs](#), [SBA Aluminum Shoulder studs](#), and [SBL Shoulder studs](#).

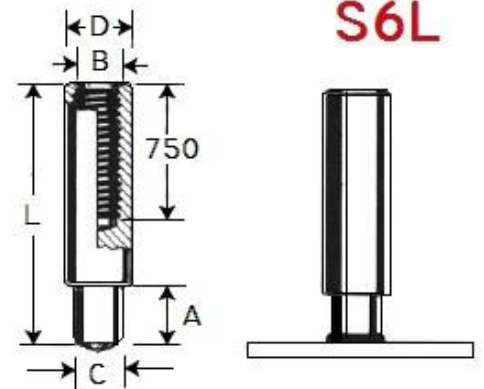

When ordering, specify: Type, Diameter, Before Weld Length, Material, Quantity, and Part Number

Example: S6L 1/2-13 x 2"; Mild Steel; 10,000 pieces; #101101006

Major Diameter	Weld Base Length	Tap Diameter	Weld Base Diameter	Length	Ferrule	Required Standard Accessories		
						Ferrule Grip	Chuck	Foot
D	A	B	C	L				
1/2	0.437	3/8-16	0.375	2.000	100101031	501001008	500001014	502001137
5/8	0.500	1/2-13	0.437	2.000	100101032	501001009	500001016	502001138
3/4	0.687	5/8-11	0.500	2.000	100101033	501001011	500001018	502001138
7/8	0.687	3/4-10	0.500	2.000	100101119	501001012	500001019	502001138

MATERIALS: Studs are available in Low Carbon Mild Steel and 18-8 Stainless Steel. Other materials are available by special order. For specific grade information and physical and chemical properties, conforming standards, and information on stud plating, please see [General Material Specifications](#).

THREADS: These threads can be internally tapped. Standard internal threads are typically UNC-2B.

FLUX: All Nelson S6L studs have a solid flux load.

Studs

Concrete Anchors

NELSON STUD WELDING SPECIFICATION

S3L Shear Connectors

Nelson headed shear connectors deliver code specified shear strength values as used in composite construction, securing concrete to steel structural components. Nelson shear connectors meet requirements of the following codes:

- AWS D1.1 Structural Welding Code – Steel, Type B
- AWS D1.6 Structural Welding Code – Stainless Steel, Type A
- AASHTO/AWS D1.5 Bridge Welding Code, Type B
- AASHTO Standard Specification for Highway Bridges
- ISO-13918 Welding – Studs for Arc Stud Welding
- Canadian Standards Association, W59 – Welded Steel Construction, Type B
- International Building Code Section 19
- AISC Manual of Steel Construction – Allowable Stress Design
- AISC Manual of Steel Construction – Load & Resistance Factor

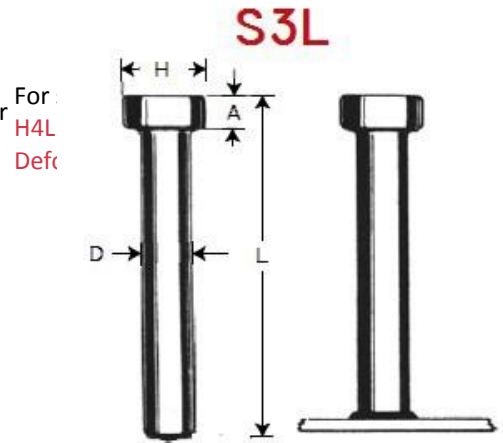

See also: ICC-ES Evaluation Report ESR-2856 Nelson Shear Connector Studs

Shear connectors are typically used in composite steel construction for holding concrete slabs to steel members to resist shear forces and increase shear loading capacity in steel buildings, bridges, columns caissons, containment liners, etc. They also act as embedment anchors on miscellaneous embedded plates, frames, angles, strip plates, attachments and connections. Options for **Welding Through Metal Deck** are available for 3/4" diameter and smaller.

When ordering, specify: Type, Diameter, Before Weld Length, Material, Quantity, and Part Number
Example: S3L 3/4 x 6-3/16"; Mild Steel; 10,000 pieces; #101098015

Stud Diameter D	Burn Off	A	H	Recommended Standard Accessories			
				Chuck	Foot	Ferrule Holder	Ferrule for Flat
3/4" / 19 mm	0.187 / 4mm	0.375	1.250	500001088	502002042	501006027	100101152
7/8" / 22mm	0.187 / 4mm	0.375	1.375	500001091	502002042	501006028	100101140
1" / 25mm	0.250 / 6mm	0.500	1.625	500001424	502002042	501006046	100101045

*Burn Off: Burn off lengths shown are for welding to bare steel. For burn off values and other details when studs are welded through metal deck to steel see **WELD THROUGH DECK SPECIFICATION SHEET**

MATERIALS: Studs are available in Low Carbon Mild Steel (ASTM A29, ASTM A108, AASHTO M169) and 316L Stainless Steel. For specific grade information and physical and chemical properties, and conforming standards, please see **General Material Specifications**. Certified Material Test Reports (CMTR) and Certificates of Compliance (COC) are available and must be requested at time of order.

For ferrules and grips used for welding through metal decking at an angle to plate, welding into angles, and welding to a vertical base plate, see the **Special Applications** section of the **Ferrule Specifications**.

FLUX: All Nelson concrete anchors have a solid flux load

Studs

Concrete Anchors

NELSON STUD WELDING SPECIFICATION

H4L Headed Concrete Anchors

Nelson headed concrete anchors deliver code specified embedded tension and shear strength values between steel and concrete. These anchors meet requirements of the following codes:

- AWS D1.1 Structural Welding Code – Steel, Type B
- AWS D1.6 Structural Welding Code – Stainless Steel, Type A
- AASHTO/AWS D1.5 Bridge Welding Code
- ISO-13918 Welding – Studs for Arc Stud Welding
- Canadian Standards Association, W59 – Welded Steel Construction, Type B
- International Building Code Section 19

See also: ICC-ES Evaluation Report ESR-2856 Nelson Shear Connectors

Headed anchors are widely used in precast, cast-in-place or composite steel construction for miscellaneous embedded plates, frames, curbing, attachments and connections.

When ordering, specify: Type, Diameter, Before Weld Length, Material, Quantity, and Part Number

Example: H4L 1/2 x 4-1/8"; Mild Steel; 5000 pieces; #101053003

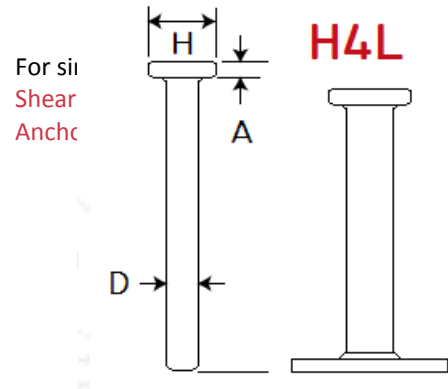

Stud Diameter D	Burn Off	A	H	Ferrule to Flat	Required Standard Accessories		
					Chuck	Foot*	Grip for Flat
1/4 / 6 mm	0.125 3 mm	0.187	0.500	100101067	500001014	502002001	501003007
3/8 / 10 mm	0.125 3 mm	0.281	0.750	100101099	500001018	502002001	501003009
1/2 / 13 mm	0.125 3 mm	0.312	1.000	100101114	500001085	502002002	501003010
5/8 / 16 mm	0.187 4 mm	0.312	1.250	100101187	500001088	502002002	501003014

*Feet 502002001 and 502002002 are used with Nelson's heavy duty gun. Feet 502002045 and 502002046 are used with Nelson's standard duty gun.

MATERIALS: Studs are available in Low Carbon Mild Steel and 316L Stainless Steel. For specific grade information and physical and chemical properties, and conforming standards, please see [General Material Specifications](#). Certified Material Test Reports (CMTR) and Certificates of Compliance (COC) are available and must be requested at time of order.

For ferrules and grips used in welding at an angle to plate, welding to angles, and welding to a vertical base plate, see the [Special Applications](#) section of the [Ferrule Specifications](#).

FLUX: All Nelson concrete anchors have a solid flux load.

Studs

Concrete Anchors

NELSON STUD WELDING SPECIFICATION

D2L Headed Concrete Anchors

Nelson deformed bar anchors deliver full tension capacity when embedded according to code requirements and provide specified shear strength when embedded at proper edge distances and spacing between bars. Nelson deformed bar anchors are used for deep embedment anchors in such applications as precast columns, tee and beam connections, seismic shear walls and securing steel plates to concrete structures. Nelson deformed bars meet requirements of the following codes:

- AWS D1.1 Structural Welding Code - Steel, Type C
- ASTM A496 Steel Wire, Deformed, For Concrete Reinforcement
- Precast/Pre-stressed Concrete Institute Design Handbook
- Canadian Standards Association, W59 - Welded Steel Construction, Type C
- International Building Code Section 19 See ICC-ES Evaluation Report ESR-2907

For similar function studs, see Nelson [B4L Reinforcing Standoff Support studs](#), [H4L Headed Concrete Anchors](#), [J2L "J" Bolt studs](#), and [S3L Shear Connectors](#).

When ordering, specify: Type, Diameter, Before Weld Length, Material, Quantity, and Part Number

Example: D2L 1/2 x 18-1/8"; Mild Steel; 5000 pieces; #101064765

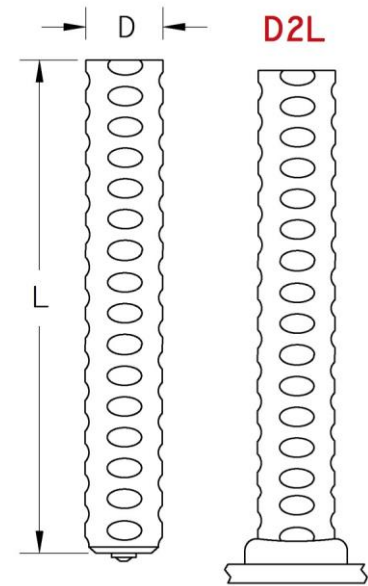

Stud Diameter D	Burn Off	Recommended Standard Accessories			
		Chuck	Grip	Ferrule	Foot
3/8 / 10 mm	0.125 / 3 mm	500001011	501003009	100101099	502002001*
1/2 / 13 mm	0.125 / 3 mm	500001014	501003010	100101114	502002002*
5/8 / 16 mm	0.187 / 4 mm	500001016	501003014	100101187	502002002*
3/4 / 19 mm	0.187 / 4 mm	500001018	501003019	100101152	502002009

*Feet 502002001 and 502002002 are used with Nelson's heavy duty gun. Feet 502002045 and 502002046 are used with Nelson's standard duty gun.

Nelson deformed bar anchors are also available on special order bent to the following shapes. Please specify bend radius, type of bend and leg length.

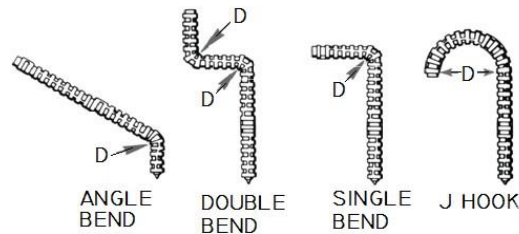

MATERIALS: Studs are available in Low Carbon Mild Steel. For specific grade information and physical and chemical properties, and conforming standards, please see [General Material Specifications](#). Certified Material Test Reports (CMTR) and Certificates of Compliance (COC) are available and must be requested at time of order.

For special ferrules and grips used in welding at an angle to plate, welding to angles, and welding to a vertical base plate, see the [Special Applications](#) section of the [Ferrule Specifications](#).

FLUX: All Nelson deformed bar anchors have a solid flux load.

Studs

Concrete Anchors

NELSON STUD WELDING SPECIFICATION

PSRS

Nelson punching shear resistor studs are specifically designed to be stud welded to a flat steel rail to provide a strong, ductile reinforcing system to prevent punching shear where columns punch through concrete cast in place, floor, and foundation slabs. Nelson punching shear resistor studs meet requirements of the following codes:

- AWS D1.1 Structural Welding Code – Steel, Type B
- ISO-13918 Welding – Studs for Arc Stud Welding
- Canadian Standards Association, W59 – Welded Steel Construction, Type B
- Canadian Standards Association, CSA A23.3 – Design of Concrete Structures
- ACI 318 – Building Code Requirements for Structural Concrete
- ACI TCR 421.1R99 Shear Reinforcement for Slabs
- ASTM A1044 – Steel Stud Assemblies for Shear Reinforcement of Concrete

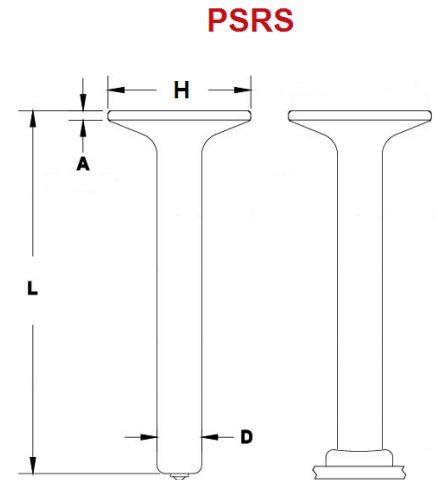

Punching shear resistor studs feature a head area 10 times the stud shank area. Due to the size of the head, the use of side grip chucks is recommended to better secure the stud during welding.

When ordering, specify: Type, Diameter, Before Weld Length, Material, Quantity, and Part Number

Example: PSRS 1/2 x 6-3/8"; Mild Steel; 10,000 pieces; #102114022

Stud Diameter D	Burn Off	A	H	Recommended Standard Accessories					
				Side Grip Chuck ¹² Assembly	Foot Adaptor Bar ³ †	Leg Bracket ³	Foot ‡	Ferrule Holder	Ferrule for Flat
3/8"	0.125 / 3mm	0.210	1.190	500014280	--	--	503000000	501003022	100101099
1/2"	0.125 / 3mm	0.280	1.580	500014281	--	--	503000000	501003021	100101114
5/8"	0.187 / 4mm	0.350	1.980	500014282	502001330	502001329	503000000	501003019	100101187
3/4"	0.187 / 4mm	0.420	2.370	500014283	502001330	502001329	503000000	501003019	100101152

¹ Multiple alternate side grip chuck designs are available. Contact your local Nelson representative for additional information

² All chucks need to be mounted on Angle Bracket #500-014-270. One or two chucks can be installed on this angle bracket

³ To weld 5/8" and 3/4" PSR studs, the Foot Adaptor Bar and Leg Bracket are needed to prevent the heads from contacting the legs

†For studs over 11" in length, the 512-193-600 3-leg tube extension kit is recommended with the appropriate length tube

‡ Foot 503-000-000 is a large split bipod foot. Foot 502-002-005 is a large split foot

MATERIALS: Studs are available in Low Carbon Mild Steel (ASTM A29, ASTM A108, AASHTO M169). For specific grade information and physical and chemical properties, and conforming standards, please see [General Material Specifications](#). Certified Material Test Reports (CMTR) and Certificates of Compliance (COC) are available and must be requested at time of order.

FLUX: All Nelson punching shear resistor studs have a solid flux load

Studs

High Strength Studs

NELSON STUD WELDING SPECIFICATION

High Strength Pitch Base

Nelson makes stud weldable, high strength studs that do not require heat treating. Consult chart, below, for a comparison of Nelson High Strength studs to SAE Grade 5 and ISO Class 8.8 bolts.

Nelson High Strength studs are available in 3/8-16 and 1/2-13 thread sizes in the CPL/CFL weld base style, and M10 metric MP/MPF weld base style.

The base material to which Nelson High Strength studs are welded must be at least 70,000 psi yield strength in order to develop the full strength of these studs.

Caution: If the High Strength studs are welded to A36 (36,000 psi) structural steel, failure may occur in the base plate at less than full stud strength.

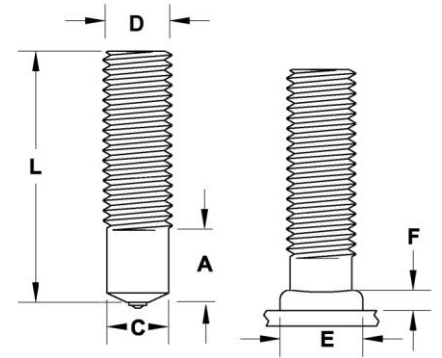

When ordering, specify: Type, Diameter, Before Weld Length, Material, Quantity, and Part Number

Example 1: CPL 1/2-13 x 1-3/4"; High Strength Steel; 1,000 pieces; #101021688

Example 2: MP M10 x 48mm; High Strength Steel; 1,000 pieces; #101021692

Thread Size D	Minimum Stud Length	Burn Off	Weld Base Length	Weld Base Diameter	Weld Flash Diameter	Weld Flash Height	Clearance	Ferrule	Required Standard Accessories		
			A	C	E	F			Chuck	Ferrule Grip	Foot Assembly
3/8-16	0.625	0.125	0.385	0.330	0.468	0.109	0.531	100101036	500001011	501001007	502001137
1/2-13	0.843	0.125	0.500	0.448	0.593	0.156	0.656	100101038	500001014	501001009	502001137
M10	16	3	11.50	8.95	12.50	3.40	14.00	100101156	500001269	501001008	502001137

MATERIALS: The physical properties of Nelson High Strength studs are shown below. For specific grade information and physical and chemical properties of other studs, as well as plating options available on these studs, please see [General Stud Specifications](#).

THREADS: Standard threads are available with up to 3" of thread length in UNC-2A coarse thread pitch and ISO R261 6g. Thread lengths greater than 3" are available as special order.

FLUX: All Nelson high strength imperial threaded and metric threaded studs have a solid flux load.

Comparison of Nelson High Strength Studs to Common Industry Specifications

Property (Minimum Values)	Nelson High Strength Studs	SAE Grade 5 Bolts	ISO 898-1, Class 8.8 Bolts
Tensile Strength	110,000†	120,000	116,000
Yield Strength	92,000	92,000	92,000
Hardness (HRC)	22-34	25-34	22-32
Elongation (2")	6.5%	14%	-
Reduction in Area	42%	35%	-

†Dependent on diameter. Consult Nelson Stud Welding for additional information.

Studs

Unthreaded

NELSON STUD WELDING SPECIFICATION

NBL Unthreaded Studs

Nelson NBL studs are designed to be welded to heavy base materials and are used for a variety of applications. In the power generation market, they are used to anchor refractory to water walls and to facilitate heat transfer in coal burning furnaces. In forging applications, NBL studs are used as the tong hold on the ends of billets. They are also commonly used as locator pins, axles, pivot points, spacers, and stops.

Studs with diameters up to 1/2", and lengths up to 1-1/4" can be specially designed for use in automatic fed stud welding equipment.

Special secondary operations, such as cross-drilling, grooving, heat treating, and pointing, can expand the application possibilities of Nelson NBL studs

For similar function studs, see Nelson [NBA Aluminum Unthreaded studs](#) and [NJL Reduced Base Unthreaded studs](#).

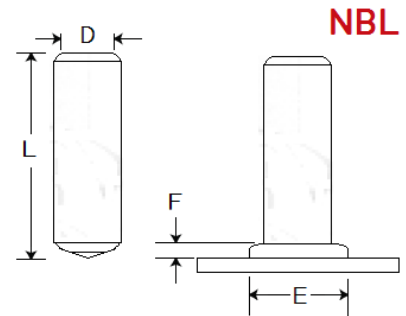

When ordering, specify: Type, Diameter, Before Weld Length, Material, Quantity, and Part Number
Example: NBL 3/8 x 1-1/8"; Stainless Steel; 10,000 pieces; #101064458

Stud Diameter D	Minimum Stud Length L	Burn Off	Weld Flash Size		Flash Clearance	Ferrule	Required Standard Accessories		
			E	F			Grip	Chuck	Foot
1/4	0.780	0.125	0.359	0.109	0.437	100101067	501001007	500001007	502001137
5/16	0.780	0.125	0.437	0.109	0.500	100101007	501001006	500001009	502001137
3/8	0.780	0.125	0.500	0.125	0.593	100101099	501001009	500001011	502001137
7/16	0.813	0.125	0.593	0.140	0.656	100101009	501001008	500001012	502001137
1/2	0.813	0.125	0.687	0.156	0.750	100101114	501001011	500001014	502001138
5/8	0.968	0.187	0.875	0.187	0.937	100101187	501001014	500001016	502001002
0.680	1.000	0.187	0.921	0.250	1.125	100101040	501001014	500001245	502001002
3/4	1.250	0.187	1.063	0.250	1.125	100101152	501001014	500001018	502001002
7/8	1.500	0.187	1.125	0.312	1.250	100101140	501001015	500001019	502001003
1	1.647	0.250	1.375	0.375	1.437	100101045	501001016	500001085	502001003

MATERIALS: Studs are available in Low Carbon Mild Steel and 430 and 300 Series Stainless Steel. Other materials are available by special order. For specific grade information and physical and chemical properties, conforming standards, and information on stud plating and heat treating, please see [General Material Specifications](#).

FLUX: All Nelson no thread studs have a solid flux load.

Studs

Unthreaded

NELSON STUD WELDING SPECIFICATION

B4L and B4P Reinforcing Standoff Support Studs

Nelson's B4L and B4P studs have a 90° bend and are used for exposed hangars and steps. They are also embedded as anchors or supports for positioning reinforcing bars. The basic stud may be an unthreaded NBL or a deformed bar anchor, D2L.

The stud burn off and weld flash information for these studs is the same diameter as NBL no thread type studs.

These Studs are usually welded using a ferrule footplate or split feet. Grips may be used if the weld leg length, "L", is long enough.

Special chucks are required to hold these studs into the stud welding gun.

Similar studs are the Nelson E2L "Eyebolt" studs, D2L Deformed Bar Anchors, H4L Headed Concrete Anchors, J2L "J" Bolt studs, R6P Rectangular Slotted studs, R9L Rope Hook studs, S3L Shear Connectors, S4X "Y" Anchor studs, and S7X Steerhorn Anchors.

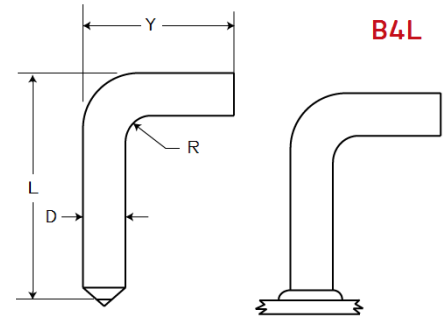

When ordering, specify: Type, Diameter, Weld Leg Length, Unwelded Leg Length, Material, Quantity, and Part Number
Example: B4L 0.250 x 1.500 x 1.312"; Mild Steel; 10,000 pieces; #101005074

Stud Diameter D	Minimum Length L	Minimum Y	R	Required Standard Accessories		
				Chuck	Ferrule	Foot Plate
1/8	1.000	1.12	0.063	500008001	100101001	501006026
3/16	1.125	1.25	0.125	500008004	100101003	501006010
1/4	1.125	1.31	0.125	500008005	100101067	501006003
5/16	1.250	1.50	0.218	500008006	100101007	501006002
3/8	1.500	1.53	0.218	500008007	100101099	501006005
7/16	1.625	1.62	0.250	500008009	100101009	501006004
1/2	1.750	1.68	0.250	500008010	100101114	501006007
5/8	1.875	2.00	0.312	500008012	100101187	501006008
3/4	2.750	2.81	0.500	500008013	100101152	501006008
7/8	3.375	3.37	0.500	500008014	100101140	501006009

MATERIALS: Studs are available in Low Carbon Mild Steel and 18-8 Stainless Steel. For specific grade information and physical and chemical properties, conforming standards, and information on stud plating, please see [General Material Specifications](#).

FLUX: All Nelson B4L and B4P studs have a solid flux load.

Studs

Unthreaded

NELSON STUD WELDING SPECIFICATION

R9L Rope Hook Studs

Nelson R9L rope hook studs are welded to trucks, trailers, and other vehicles to provide a means of securing tarpaulins with ropes. Because the studs can be rapidly applied, compared to manual welding of J-bent rods, the R9L studs are ideal in situations where large quantities of studs must be applied.

Additionally, Nelson R9L studs can be welded to the perimeter of multistory buildings to facilitate the securing of ropes during building construction. R9L studs meet OSHA regulations for such applications.

Stud types that may perform a similar function to the Nelson R9L studs are Nelson **B4L Reinforcing Standoff Support studs**, **E2L "Eyebolt" studs**, **J2L "J" Bolt studs**, and **R7P Rectangular Stud with Hole**.

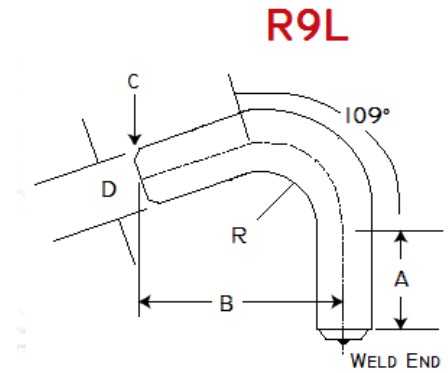

When ordering, specify: Type, Description, Material, Quantity, Part number

Example: R9L .448" x 3"; Mild Steel; 10,000 pieces; # 101092002

Stud Description	A	B	C	Stud Diameter D	R	Required Standard Accessories		
						Ferrule	Chuck Assembly	Foot Plate
.448 x 3	0.687	1.875	45° x 0.031	0.448	0.500	100101118	500015111	501006011

MATERIALS: Studs are available in Low Carbon Mild Steel and 18-8 Stainless Steel. For specific grade information and physical and chemical properties, conforming standards, and information on stud plating and heat treating, please see [General Material Specifications](#).

FLUX: All Nelson R9L studs have a solid flux load.

Studs

Unthreaded

NELSON STUD WELDING SPECIFICATION

XBL and XXL Round Corner Square Studs

Nelson XBL and XXL Round Corner Square studs are a patented product developed for the installation of hanging overhead wire ways in ships. The round weld base facilitates welding in all positions, while the 3/4" round corner square upper section of the stud and cross-drilled holes provide an attachment point for a variety of mounting hardware. Such hardware may be used to attach cable trays, light fixtures, ducts, and pipes.

The cross bolt holes in Nelson XBL and XXL studs are accessible after 1 or 2 inches of insulation has been installed. This design permits flexibility in construction and repair scheduling, which is not possible when brackets are welded directly to the ship's structure. The standard holes accommodate 3/8-16 bolts and are spaced 1" apart.

The XBL series of studs have full diameter weld bases, while the XXL studs have reduced weld bases. The smaller 1/2" diameter weld bases are used for individual light fixtures and permit welding with smaller power sources.

Longer round corner square studs and different hole diameters and spacing can be applied. Nelson Round Corner Square studs have been shock and vibration tested and are Navy approved.

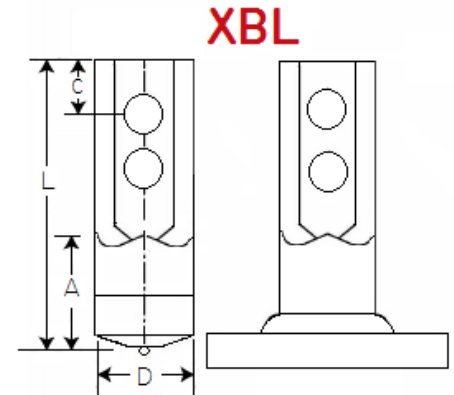

When ordering, specify: Type, Square Size, Overall Length, Weld Base Diameter, Number of Holes, Material, Quantity, Part Number
Example: XXL 3/4" square x 2-1/4" long x 1/2" weld base diameter; 2 holes; Mild Steel; 5,000 pieces; #101017193

Type	Base Dia. D	Minimum Base A	Holes	Length L	Hole to End C	Required Standard Accessories		
						Ferrule	Ferrule Grip	Chuck
XXL	1/2"	1.625	1	3.562	0.437	10010259	501001014	500007035
XXL	1/2"	2.000	2	4.062	0.375	10010111	501001011	500007035
XBL	3/4"	1.125	2	3.062	0.375	10010152	501001014	500007035

MATERIALS: Studs are available in Low Carbon Mild Steel. The option for electro-zinc plating coating is available. For specific grade information, physical and chemical properties, conforming standards, and information on stud plating and heat treating, please see [General Material Specifications](#).

FLUX: All Nelson XXL and XBL studs have a solid flux load.

Studs

Unthreaded

NELSON STUD WELDING SPECIFICATION

J2L "J" Bolt Studs

Nelson J2L (and J2P, 3/16" diameter) studs are welded to parts, assemblies, and structures to act as an attachment or lifting point. They may be embedded in concrete to provide anchorage, or may be used as locators for reinforcing bars in concrete structures.

Special chucks that fit the curve of the "J" are made to weld these studs. The chucks shown are for studs with the minimum radius J bend. If the length, "E", is more than 4", then side-gripping chucks can be used. The weight surface of the J2L deformed bar anchor studs is better gripped by the two ball detents and lever screw of the side gripping chucks which are mounted on angle bracket #528-001-098.

The foot plates or split feet/grip combinations shown can be used to weld J2L studs. Please see the NBL type specification sheet for the weld burn off and weld flash dimensions of Nelson J2L and J2P studs.

J2L studs are also made from

Stud types that may perform a similar function to the J2L "J" Bolt studs are Nelson **B4L Reinforcing Standoff Support studs**, **E2L "Eyebolt" studs**, **R7P Rectangular Stud with Hole**, and **R9L Rope Hook studs**.

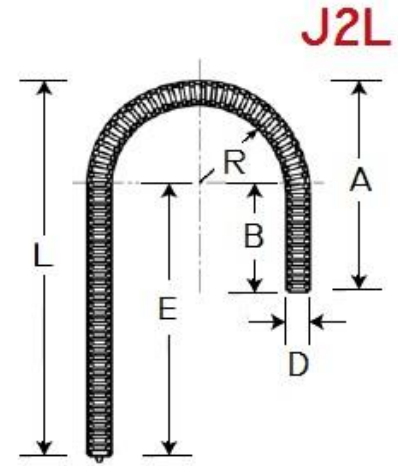

When ordering, specify: Type, Diameter, Length "A", Length "C", Radius, Material, Quantity, Part Number

Example: J2L 1/4 x 2", 1.187 x 0.625, 0.400"; Mild Steel; 10,000 pieces; #101058036

Stud Diameter	Minimum L	Minimum A	Minimum B	Minimum E	Minimum R	Required Standard Accessories		
						Chuck for Minimum Radius	Ferrule	Plate Foot Assembly
1/4	1.187	1.062	0.500	0.625	0.312	500012002	100101067	501006003
3/8	1.562	1.312	0.500	0.750	0.437	500012008	100101099	501006005
7/6	1.750	1.437	0.500	0.812	0.500	500012011	100101009	501006004
1/2	1.937	1.500	0.500	0.937	0.500	500012005	100101114	501006007
5/8	2.437	1.875	0.500	1.062	0.750	500012001	100101187	501006008
3/4	3.250	2.750	1.000	1.000	1.000	See Side Gripping	100101152	501006008

MATERIALS: Studs are available in Low Carbon Mild Steel (with or without deformations), high strength deformed steel bars meeting ASTM A1064 and 18-8 Stainless Steel. For specific grade information and physical and chemical properties, conforming standards, and information on stud plating and heat treating, please see **General Material Specifications**.

FLUX: All standard Nelson J2L "J" Bolt studs have a solid flux load

Side Gripping Chucks (for J2L or D2L with large radius)

Stud Diameter	Chuck Assembly	Body Only
1/4	500014103	500014100
3/8	500014102	500014099
1/2	500014095	500014092
5/8	500014096	500014093
3/4	500014097	500014094

American Concrete Institute ACI 318 calls for the following minimum radiuses in 180° bent hooks:

Bar Diameter	Hook - 6 x D Radius - Diameter
#3 - 3/8"	1-1/8" - 2-1/2"
#4 - 1/2"	1-1/2" - 3"
#5 - 5/8"	1-7/8" - 3-3/4"
#6 - 3/4"	2-1/4" - 4-1/2"

Studs

Unthreaded

NELSON STUD WELDING SPECIFICATION

E2L “Eyebolt” Studs

Nelson E2L (and E2P, 3/16” diameter) studs are welded a variety of parts or structures to provide a means of attachment to the assembly or a means of lifting parts.

The length of the weld base portion of the stud is needed for the ferrule height and the burn off, or length reduction, during the stud welding process. The weld flash dimensions and burn off are the same as for Nelson’s NBL type studs.

Special chucks are used to grip the eye portion of the studs and ferrule foot plates are used to grip the ferrule below the eye.

For similar shape and function studs, please see Nelson [B4L Reinforcing Standoff Support studs](#), [J2L “J” Bolt studs](#), [H4L Headed Concrete Anchors](#), [R9L Rope Hook studs](#), and [R7P Rectangular Stud with Hole](#).

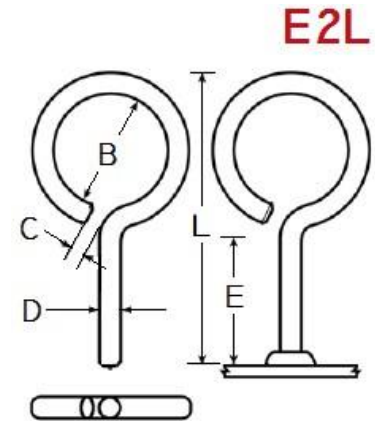

When ordering, specify: Type, Diameter, Length, Length, Material, Quantity, Part Number

Example: E2L 0.250 x 2.000”; Mild Steel; 10,000 pieces; #101028045

Stud Diameter D	Minimum Dimension			Maximum Opening C	Required Standard Accessories		
	Length L	B	E		Chuck for Minimum Radius	Ferrule	Foot Assembly
3/16	1.875	0.750	0.750	0.187	500011002	100011003	501006010
1/4	1.750	0.500	0.750	0.250	500011003	100011067	501006003
5/16	1.812	0.437	0.750	0.312	500011004	100011007	501006002
3/8	2.562	0.875	0.937	0.375	500011005	100011099	501006005
7/16	3.000	1.000	1.125	0.437	500011006	100011009	501006004
1/2	3.562	1.250	1.312	0.500	500011007	100011114	501006007

MATERIALS: Studs are available in Low Carbon Mild Steel and 18-8 Stainless Steel. For specific grade information and physical and chemical properties, conforming standards, and information on stud plating and heat treating, please see [General Material Specifications](#).

FLUX: All Nelson E2L studs have a solid flux load.

Studs

Unthreaded

NELSON STUD WELDING SPECIFICATION

NJL Reduced Base Unthreaded Studs

NJL unthreaded studs have a reduced weld base diameter, A, to produce a smaller weld flash diameter than when the full base Nelson NBL no thread studs are used. The smaller weld flash allows the use of smaller clearance holes. The strength of the assembly is determined by the area of the reduced weld base rather than the thread area.

For similar function studs, see Nelson [NBA Unthreaded Aluminum studs](#) and [NBL Unthreaded studs](#).

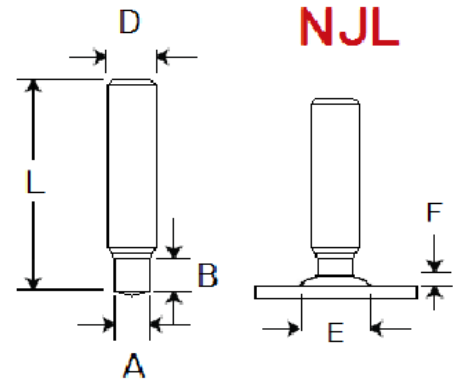

When ordering, specify: Type, Diameter, Before Weld Length, Material, Quantity, Part Number

Example: NJL 0.250 x 1"; Mild Steel; 10,000 pieces

Major Diameter D	Minimum Length L	Weld Base Diameter A	B	Weld Flash Dimensions			Burn Off	Required Standard Accessories			
				Diameter E	Height F	Clearance Diameter		Ferrule	Ferrule Grip	Chuck	Foot
1/4	0.827	0.187	0.187	0.281	0.093	0.328	0.093	100101016	501001005	500001007	502001137
5/16	0.827	0.218	0.203	0.343	0.093	0.390	0.093	100101017	501001006	500001009	502001137
3/8	0.827	0.275	0.218	0.437	0.109	0.469	0.125	100101018	501001007	500001011	502001137
7/16	0.922	0.343	0.250	0.531	0.125	0.594	0.125	100101019	501001008	500001016	502001137
1/2	0.922	0.390	0.281	0.548	0.140	0.609	0.125	100101020	501001009	500001014	502001137
5/8	0.968	0.500	0.312	0.656	0.156	0.718	0.156	100101021	501001011	500001016	502001138
3/4	1.172	0.625	0.343	0.813	0.187	0.875	0.187	100101022	501001014	500001018	502001002
7/8	1.406	0.750	0.390	0.937	0.250	1.000	0.187	100101023	501001015	500001019	502001003

MATERIALS: Studs are available in Low Carbon Mild Steel and 18-8 Stainless Steel. Other materials are available by special order. For specific grade information and physical and chemical properties, conforming standards, and information on stud plating, please see [General Material Specifications](#).

FLUX: All Nelson NJL studs have a solid flux load.

Studs

Unthreaded

NELSON STUD WELDING SPECIFICATION

S2L Setlok Studs

Nelson S2L studs are welded to the structural steel on spacing that matches the pitch of the corrugated sheet metal. The Nelson S2L and Setlok cap system provides a quick, reliable and weatherproof roof or wall construction system. These studs and caps are also used to cover and insulate oil storage tanks.

5/16" impression speed clips, #301001008, are used to retain the insulation until the flat or corrugated covering sheet is applied.

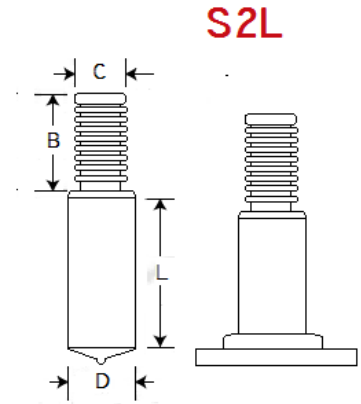

For similar function studs, see Nelson [N3P Navy Type Annular Ring Insulation Pins](#).

When ordering, specify: Type, Diameter, Length to Shoulder, Extension Length, Material, Quantity, Part Number

Example: S2L 5/16 x 1"; 3/8"; Stainless Steel; 5,000 pieces; #101097280

Stud Diameter D	C	B*	Length L	Required Standard Accessories			
				Ferrule	Ferrule Grip	Chuck	Foot
5/16	0.187	0.375	0.687	501101007	501001001	500001006	502001137
5/16	0.187	0.375	0.968	501101007	501001001	500001006	502001137

*B length for 4 laps of 18-gauge material is 0.437"

Length described above is before weld length. The 0.687" length is for all 2-2/3" pitch corrugated steel studs. The 0.968" length is for all 0.032", 2-2/3" pitch corrugated aluminum studs.

MATERIALS: Studs are available in Low Carbon Mild Steel and Stainless Steel. For specific grade information, physical and chemical properties, conforming standards, and information on stud plating, please see [General Material Specifications](#).

RECOMMENDED ACCESSORIES SPECIFICATION

Setlok Caps and Speed Clips

Nelson Setlok Caps are engineered for use in conjunction with Nelson S2L Setlok studs to provide a weatherproof securing option. A rubber-faced hammer is used to impale the sheet metal over the ends of the studs. After the annular rings are exposed, a setting tool and hammer are used to lock the caps onto the studs.

Speed clips can be used in combination with S2L studs to temporarily retain all types of material that can be readily impaled (fiberglass, foam, felts, and corks, as well as refractory linings and light-density insulation board) until the sheet metal and caps are installed.

When ordering, specify: Type, Description, Material, Quantity
Example: 5/16" Speed Clip; Aluminum; 10,000 pieces; #101301008

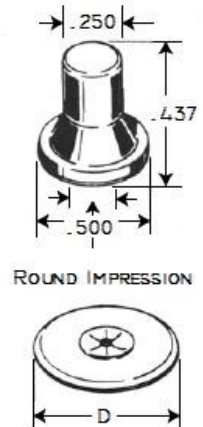

Accessory Description	Pin size C	Clip Diameter D	Clip Thickness	Part Number
Setlok Cap	3/16	1/2	0.437	101304001
Setlok Speed	5/16	1-3/8	0.021	101301008
Setlok Setting	--	--	--	505001012

Studs

Metric Drawn Arc

NELSON STUD WELDING SPECIFICATION

MP Partially Threaded Studs

Nelson Metric MP studs are the standard metric stud recommended for fastening applications on heavy gauge base materials where development of the full fastener strength is needed. The unthreaded section minimizes the weld flash diameter and height. It also reduces the possibility of stud hang up in the ferrule cavity if gun parts are slightly misaligned.

Nelson partially threaded studs have a pitch diameter weld base and are available in thread diameters of M6 through M24 with unlimited length.

Nelson MP studs are certified to AWS D1.1, TS16949, and ISO 13918.

For similar function metric studs, see Nelson [MD Fully Threaded Metric Studs](#) and [MR Reduced Base studs](#). In the imperial line of Nelson studs, see [CFL Full Threaded studs](#), [CFP Small Diameter Threaded studs](#), [CJL Reduced Base studs](#), [HBL Full Base](#)

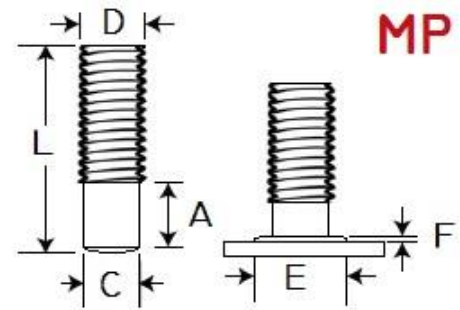

When ordering, specify: Type, Diameter, Before Weld Length, Material, Quantity, Part Number
Example: MP M10 x 1.50 x 28mm; Mild Steel; 10,000 pieces; #101018221

Thread Size D	Minimum Stud Length L	Burn Off	C	A	Weld Flash Size		Flash Clearance	Recommended Standard Accessories			
					Diameter E	Height F		Ferrule	Grip	Chuck	Foot
M6 x 1.00	15.00	2.00	5.30	9.50	9.00	2.80	10.00	100101034	501001005	500001267	502001137
M8 x 1.25	16.00	3.00	7.10	11.00	9.90	2.80	10.90	100101035	501001006	500001009	502001137
M10 x 1.50	16.00	3.00	8.90	11.50	12.50	3.40	13.70	100101156	501001008	500001269	502001137
M12 x 1.75	24.00	3.00	10.70	14.00	14.50	4.50	16.00	100101032	501001009	500001206	502001137
M16 x 2.00	29.00	4.00	14.60	16.50	17.80	5.80	20.00	100101039	501001011	500001016	502001138
M20 x 2.50	35.00	4.00	18.20	19.00	27.00	6.30	28.60	100101133	501001015	500001272	502001003
M24 x 3.00	46.00	5.00	21.90	27.00	28.60	8.00	31.80	100101140	501001015	500001085	502001003

MATERIALS: Studs are available in Low Carbon Mild Steel and Stainless Steel. For specific grade information, physical and chemical properties, conforming standards, and information on stud plating, please see [General Material Specifications](#).

THREADS: Standard MP studs are available with up to 75mm of thread length in ISO 13918 6g series thread. Other thread pitch series, and thread lengths greater than 75mm are available as special order.

FLUX: All Nelson partially threaded MP studs have a solid flux load.

Studs

Metric Drawn Arc

NELSON STUD WELDING SPECIFICATION

MPF Threaded Studs

Nelson Metric MPF studs have a short unthreaded weld base such that after welding the usable threads essentially extend down to the weld metal. They are used for fastening applications on heavy gauge base materials where development of the full fastener strength is needed. The short unthreaded section minimizes the weld flash diameter and height. It also reduces the possibility of stud hang up in the ferrule cavity if gun parts are slightly misaligned. Ferrules with a special low profile and large diameter are used to weld MPF style studs.

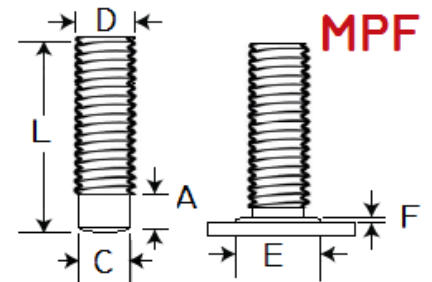

Nelson partially threaded studs have a pitch diameter weld base and are available in thread diameters of M6 through M16 with unlimited length.

Nelson MPF studs conform to AWS D1.1, TS16949, and ISO 9000:2000.

For similar function metric studs, see Nelson [MD Fully Threaded Metric studs](#), [MP Partially Threaded studs](#), and [MR Reduced Base studs](#). In the imperial line of Nelson studs, see [CFL Full Threaded studs](#), [CFP Small Diameter Threaded studs](#), [CJL Reduced Base studs](#), [HBL Full Base Diameter Threaded studs](#), [B5L 90° Bent Collar studs](#), [Banding Cable Hangers](#), [CrimpLok™ Cable Hangers](#), and [Watertight nuts](#).

When ordering, specify: Type, Diameter, Before Weld Length, Material, Quantity, Part Number

Example: MPF M10 x 58mm; Stainless Steel; 10,000 pieces; #102600013

Thread Size D	Minimum Stud Length	Burn Off	C	A	Weld Flash Size		Flash Clearance	Required Standard Accessories			
					Diameter E	Height F		Ferrule	Grip	Chuck	Foot
M6 x 1.00	17.00	2.00	5.30	3.50	9.00	2.80	10.00	100101188	501001005	500001267	502001137
M8 x 1.25	18.00	3.00	7.10	6.90	9.90	2.80	10.90	100101209	501001008	500001009	502001137
M10 x 1.50	18.00	3.00	8.90	8.80	12.50	3.40	13.70	100101210	501001009	500001269	502001137
M12 x 1.75	23.00	3.00	10.80	9.00	14.50	4.50	16.00	100101211	501001011	500001206	502001137
M16 x 2.00	29.00	4.00	14.60	13.50	17.80	5.80	20.00	600565	501001014	500001016	502001138

MATERIALS: Studs are available in Low Carbon Mild Steel and Stainless Steel. For specific grade information, physical and chemical properties, conforming standards, and information on stud plating and heat treating, please see [General Material Specifications](#).

THREADS: Standard MPF studs are available in lengths up to 50mm. The threads conform to ISO 13918 6g series.

FLUX: All Nelson threaded MPF studs have a solid flux load.

Studs

Metric Drawn Arc

NELSON STUD WELDING SPECIFICATION

MD Fully Threaded Studs

Nelson MD studs are recommended for fastening applications where threads are needed for the full fastener length. MD studs are available in thread diameters of M6 through M24. Nelson fully threaded studs have a short length of pitch diameter weld base. Most of this length is melted off during the stud welding process so that usable thread extends down to the top of the weld flash on installed studs. Nelson MD Studs conform to AWS D1.1, TS 16949 and ISO 13918.

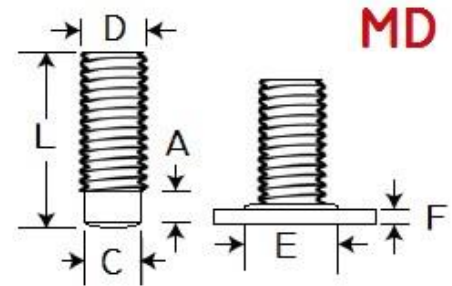

For similar function metric studs, see Nelson [MP Partially Threaded studs](#) and [MR Reduced Base Threaded studs](#). In the imperial line of Nelson studs, see [CFP Small Diameter Threaded studs](#), [CFL Fully Threaded studs](#), [HBA Aluminum Full Base Diameter Threaded studs](#), [HBL Full Base Diameter Threaded studs](#), [Banding Cable Hangers](#), [CrimpLok™ Cable Hangers](#), and [Watertight nuts](#).

When ordering, specify: Type, Diameter, Before Weld Length, Material, Quantity, Part Number

Example: MD M16 x 2.00 x 34.00mm; Mild Steel; 10,000 pieces; #101012903

Thread Size D	Minimum Stud Length L	A	Burn Off	C	Weld Flash Size		Flash Clearance	Required Standard Accessories			
					Diameter E	Height F		Ferrule	Grip	Chuck	Foot
M5 x 0.80	15	4.00	2.00	4.40	7.90	2.50	9.50	100101034	501001005	500001427	502001137
M6 x 1.00	20	4.00	2.00	5.30	9.10	3.00	11.10	100101067	501001007	500001267	502001137
M8 x 1.25	20	4.00	3.00	7.10	11.00	3.50	12.70	100101024	501001006	500001009	502001137
M10 x 1.50	22	5.00	3.00	8.99	12.30	4.00	13.90	100101240	501001008	500001269	502001137
M12 x 1.75	22	6.00	3.00	10.80	16.00	4.50	17.50	100101027	501001009	500001206	502001137
M16 x 2.00	27	6.00	4.00	14.60	20.50	7.00	22.00	100101028	501001011	500001016	502001002
M20 x 2.50	30	7.00	5.00	18.30	26.00	9.00	27.50	100101238	501001014	500001272	502001002
M24 x 3.00	38	8.00	6.00	22.00	35.00	10.00	36.50	100101045	501001016	500001085	502001003

MATERIALS: Studs are available in Low Carbon Mild Steel and Stainless Steel. For specific grade information, physical and chemical properties, conforming standards, and information on stud plating, please see [General Material Specifications](#).

THREADS: Standard MD studs are available with up to 75mm of thread length in ISO 13918 6g series thread. Other thread pitch series, and thread lengths greater than 75mm are available as special order.

FLUX: All Nelson partially threaded MD studs have a solid flux load.

Special Ferrules for Shorter Studs

Thread Size	Minimum Stud Length	Required Standard Accessories		
		Ferrule	Grip	Foot
M5 x 0.80	12	100101066	501001011	502001138
M6 x 1.00	12	100101077	501001006	502001137
M8 x 1.25	13	100101030	501001007	502001137
M10 x 1.50	16	100101032	501001009	502001137
M12 x 1.75	18	100101119	501001012	502001137
M16 x 2.00	20	100101126	501001012	502001138
M20 x 2.50	N/A	—	—	—
M24 x 3.00	N/A	—	—	—

Studs

Metric Drawn Arc

NELSON STUD WELDING SPECIFICATION

MR Reduced Base Studs

Nelson metric MR threaded studs have a reduced weld base diameter, C, to produce a smaller weld flash diameter than when Nelson Pitch Diameter MP or CPL studs are used. The smaller weld flash allows the use of smaller clearance holes. The strength of the assembly is determined by the area of the reduced weld base rather than the thread area.

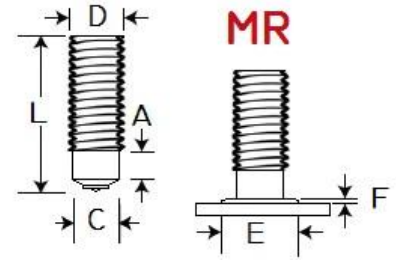

Nelson MR Studs conform to AWS D1.1, TS 16949 and ISO 13918.

For similar function metric studs, see Nelson **MD Fully Threaded studs**, and **MP Partially Threaded studs**. In the imperial line of Nelson studs, see **CPL Partially Threaded studs**, **CFP Small Diameter Threaded studs**, **HBA Full Base Diameter Aluminum studs**, and **HBL Full Base Diameter studs**.

When ordering, specify: Type, Diameter, Before Weld Length, Material, Quantity, Part Number

Example: MR M16 x 2.00 x 54mm; Mild Steel; 10,000 pieces; #102601015

Thread Size D	Minimum Length L	Weld Base Diameter C	Weld Base Length A	Weld Flash Dimensions			Burn Off	Recommended Standard Accessories			
				Diameter E	Height F	Clearance Diameter		Ferrule	Ferrule Grip	Chuck	Foot
M6 x 1.00	17.00	4.70	4.00	6.70	2.50	8.30	2.00	100101016	501001005	500001267	502001137
M8 x 1.25	17.00	6.20	4.50	8.80	2.50	9.90	3.00	100101017	501001006	500001009	502001137
M10 x 1.50	22.00	7.90	5.00	11.00	3.00	12.50	3.00	100101164	501001008	500001269	502001137
M12 x 1.75	25.00	9.50	6.50	13.00	4.00	14.80	3.00	100101165	501001009	500001206	502001137
M16 x 2.00	33.00	13.20	8.00	17.00	5.00	18.20	4.00	100101021	501001011	500001016	502001002
M20 x 2.50	34.00	16.50	14.50	21.00	6.00	23.20	5.00	100101246	501001014	500001272	502001002

MATERIALS: Studs are available in Low Carbon Mild Steel and Stainless Steel. Other materials are available by special order. For specific grade information and physical and chemical properties, conforming standards, and information on stud plating, please see [General Material Specifications](#).

THREADS: Standard MR studs are available with up to 75mm of thread length in ISO 13918 6g series thread. Other thread pitch series, and thread lengths greater than 75mm are available as special order.

FLUX: All Nelson MR studs have a solid flux load.

Studs

Metric Drawn Arc

NELSON STUD WELDING SPECIFICATION

CKL Collar Studs

Nelson metric CKL collar studs are used to mount circuit boards and panels where a stand-off is desired. They are also used to retain cables or hoses using a clip. The thread extension speeds assembly over installing a bolt into an internal threaded boss or tapped stud.

Nelson CKL Studs conform to AWS D1.1, TS 16949 and ISO 13918.

The ferrules supplied with CKL studs have gripping neck diameters larger than the collar diameter, G. This allows the gun to strip straight off the welded studs.

For similar function, see Nelson [B5L 90°Bent Collar Studs](#), [Banding Cable Hangers](#), [CKA Aluminum Collar studs](#), [CrimpLok™ Cable Hangers](#), [Grounding studs](#), [SBA Aluminum Shoulder Studs](#), [SBL Shoulder Studs](#), and [TBL Internally Threaded studs](#).

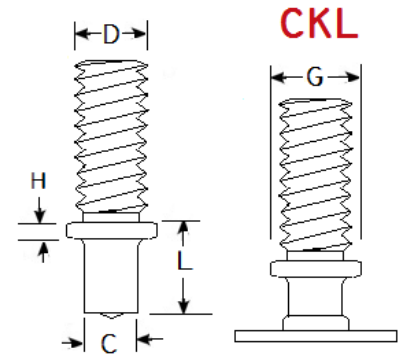

When ordering, specify: Type, Base Diameter, Base Length, Thread Size, Thread Length, Material, Quantity, Part Number
Example: CKL M10 x 1.50; 9 x 16.00mm; Mild Steel; 10,000 pieces; #101016538

Thread Size D	Base C	Minimum Base Length L	Collar		Required Standard Accessories			
			G	H	Ferrule	Ferrule Grip ¹	Chuck	Foot ¹
M6 x 1.00	5.30	13.00	13.00	2.50	100101066	501001011	500001267	502001138
M8 X 1.25	7.10	13.00	14.00	2.50	100101209	501001008	500001009	502001137
M10 X 1.50	8.90	13.00	16.00	2.50	100101210	501001009	500001269	502001137
M12 X 1.75	10.80	13.00	19.00	2.50	100101211	501001011	500001206	502001138

¹For dimensions of the weld flash, refer to [MP Metric Studs](#).

Thread Size	Ferrule	Neck Dia.	Foot Plate ¹
M6	100101066	0.785	501006007
M8	100101209	0.585	501006004
M10	100101210	0.650	501006005
M12	100101211	0.785	501006007

¹Ferrule footplates can be used in place of ferrule grips and feet when welding CKL studs

MATERIALS: Studs are available in Low Carbon Mild Steel and 18-8 Stainless Steel. Other materials are available by special order. For specific grade information and physical and chemical properties, conforming standards, and information on stud plating and heat treating, please see [General Material Specifications](#).

THREADS: Standard metric CKL studs are available with standard thread length of 10, 12, 16, 20, 25, 30 and 35 mm. in ISO 13918 6g series thread. Other thread pitch series, and thread lengths greater than 75mm are available as special order.

FLUX: All Nelson CKL studs have a solid flux load.

Studs

Metric Drawn Arc

NELSON STUD WELDING SPECIFICATION

NBL Unthreaded Studs

Nelson metric NBL studs are designed to be welded to heavy base materials and are used for a variety of applications. In the power generation market, they are used to anchor refractory to water walls and to facilitate heat transfer in coal burning furnaces. In forging applications, NBL studs are used as the tong hold on the ends of billets. They are also commonly used as locator pins, axles, pivot points, spacers, and stops.

Studs with diameters up to 12.7mm, and lengths 30mm can be specially designed for use in automatic fed stud welding equipment.

Special secondary operations, such as cross-drilling, grooving, heat treating, and pointing can expand the application possibilities of Nelson NBL studs.

For similar function imperial studs, see Nelson [NBA Aluminum Unthreaded studs](#) and [NJL Reduced Base Unthreaded studs](#).

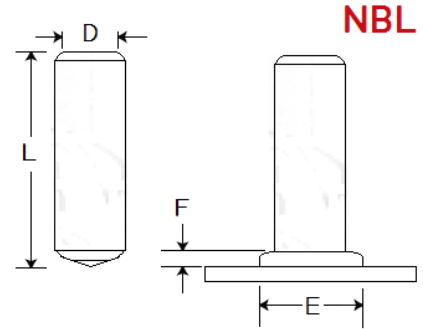

When ordering, specify: Type, Diameter, Before Weld Length, Material, Quantity, Part Number

Example: NBL 10 x 20mm; Stainless Steel; 10,000 pieces; #101065913

Stud Diameter D	Minimum Stud Length L	Burn Off mm	Weld Flash Size		Flash Clearance	Required Standard Accessories			
			F	G		Ferrule	Grip	Chuck	Foot
6	18	2	9.10	3	11.10	100101067	501001007	500001267	502001137
8	23	3	11	4	12.50	100101007	501001006	500001009	502001137
10	23	3	13	4	14.50	100101037	501001008	500001269	502001137
12	24	3	16	4.5	17.50	100101027	501001009	500001206	502001137
16	29	4	21	6	22.50	100101187	501001014	500001016	501001138
19	30	5	27	7	28.50	100101152	501001014	500001018	502001002
20	30	5	26	8	27.50	100101195	501001014	500001272	502001002
22	35	6	28	9	30.50	100101140	501001015	500001019	502001003
24	36	6	35	10	36.50	100101197	501001016	500001274	502001003

MATERIALS: Studs are available in Low Carbon Mild Steel and 18-8 Stainless Steel. Other materials are available by special order. For specific grade information and physical and chemical properties, conforming standards, and information on stud plating, please see [General Material Specifications](#).

FLUX: All Nelson unthreaded studs have a solid flux load.

Studs

Metric Drawn Arc

NELSON STUD WELDING SPECIFICATION

Metric TBL Internally Threaded Studs

Nelson's internally threaded TBL studs are intended to be used on heavy base materials and serve as a means of attaching or anchoring components to a structure. When maximizing the stud diameter to tap ratio, the stud can also serve as a stand-off post.

Standard TBL studs have internal metric ISO 6g threads.

The "E" dimension is predicated on stud diameter, not tap size. To reduce the "I" dimension, secondary bottom tapping or flat bottom drilling is available as a special order with significant price additions.

Reduced base studs are available but depth of tap drill point should not pass below shoulder of reduced diameter shoulder so that stud strength is not compromised.

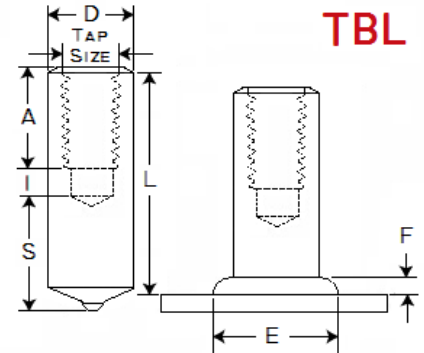

For similar function imperial studs, see Nelson [CKL Collar studs](#), [NBL Unthreaded studs](#), [S6L Sprinkler studs](#), and [SBL Shoulder studs](#).

When ordering, specify: Type, Diameter, Before Weld Length, Tap Size, Material, Quantity, Part Number

Example: TBL M8 x 22.00mm, with 8mm Deep Tap; Mild Steel; 10,000 pieces; #101103481

Stud Diameter D	Maximum Tap Size C	Minimum Values				Burn Off	Weld Flash		Flash Clearance	Recommended Standard Accessories			
		D	A	I	S		E	F		Ferrule	Grip	Chuck	Foot
6	M4 x 0.70	6.00	6.00	3.25	4.00	2.00	9.10	3.00	11.10	100101067	501001007	500001267	502001137
8	M5 x 0.80	8.00	8.00	3.75	4.00	3.00	11.00	4.00	12.50	100101007	501001006	500001009	502001137
10	M6 x 1.00	10.00	9.00	4.50	4.00	3.00	13.00	4.00	14.50	100101037	501001008	500001269	502001137
12	M8 x 1.25	12.00	12.00	6.00	5.00	3.00	16.00	4.50	17.50	100101027	501001009	500001206	502001137
16	M10 x 1.50	16.00	15.00	7.75	6.00	4.00	21.00	6.00	22.50	100101187	501001014	500001016	502001138
19	M12 x 1.75	19.00	18.00	9.25	6.00	5.00	27.00	7.00	28.50	100101152	501001014	500001018	502001002
22	M16 x 2.00	22.00	24.00	11.5	7.00	6.00	28.00	9.00	30.50	100101140	501001015	500001019	502001003

In the table above, E represents the weld flash diameter; F, the weld flash height; I, the imperfect thread depth; and S, the depth of the solid weld base.

MATERIALS: Metric TBL studs are available in Low Carbon Mild Steel and 18-8 Stainless Steel. For specific grade information and physical and chemical properties, conforming standards, and information on stud plating, please see [General Material Specifications](#).

THREADS: Standard metric threads meet ISO 6g.

FLUX: All standard Nelson internally threaded studs have a solid flux load.

Studs

Automotive

NELSON STUD WELDING SPECIFICATION

AXC "Fir Tree" Studs

Nelson AXC "Fir Tree" studs are normally welded to bare or corrosion protection treated automobile sheet metal using the drawn arc stud welding process. This process, also known as the short cycle welding process, uses a Nelson rectifier power source at short time and high amperage settings.

The special thread design is engineered for use with a variety of plastic or metal clips. The Nelson Fir Tree thread is designed to reduce assembly time and provide positive attachment. The "push-on" thread shape of these studs, when used with the lightweight, versatile clips, provides many fastening solutions for securing hydraulic lines, hoses, wiring, and insulation.

Fir Tree studs are designed to be welded with Nelson Stud Welding systems that automatically feed the studs to the weld gun.

For similar function studs, see Nelson [ANC Unthreaded Stored Arc™ studs](#), [ATC Threaded Stored Arc™ studs](#), [Grounding studs](#), [H8X "T" studs](#), [TATC Auto-Feed Capacitor Discharge studs](#), [TFNC Flanged Capacitor Discharge studs](#), [TFTC Flanged Capacitor Discharge studs](#), [TUTC Unflanged Capacitor Discharge Studs](#), and ["W" Top Wide Flange studs](#).

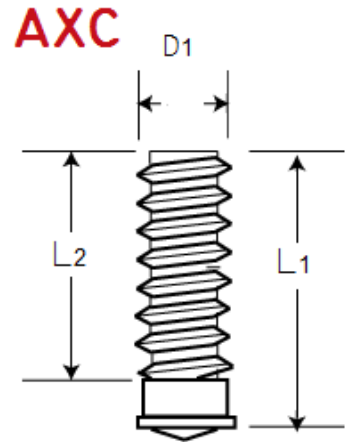

When ordering, specify: Type, Description, Material, Quantity, Part Number

Example: AXC 5mm x 9mm; Mild Steel; 10,000 pieces; #101211120

D1	Minimum L1	Minimum L2
5	9	6

MATERIALS: Studs are available in plated Low Carbon Mild Steel and Stainless Steel. For specific grade information and physical and chemical properties, conforming standards, and information on stud plating, please see [General Material Specifications](#).

Studs

Automotive

NELSON STUD WELDING SPECIFICATION

Grounding Studs

Nelson Grounding studs are used to make electrical contact in automotive and industrial applications. Plastic parts and housings or painted surfaces may isolate subassemblies, such as taillights from the chassis, thus preventing them from being grounded. The flange and threads on Nelson grounding studs provide an attachment point for cables between the chassis and the isolated component.

Nelson Grounding studs are welded using the Short Cycle process, which allows the studs to be welded to thin base material with good strength. They are supplied with a plastic caps or metal acorn nuts installed on them, facilitating the automatic feeding of the stud to the weld gun and protecting the stud's threads and flange surface during subsequent assembly painting. When the caps are removed after painting, the threads and flange are paint free and ready for electrical cable attachment. The caps or nuts are color-coded to assist the operator in identifying thread size, material, and plating.

Nelson Grounding studs can be supplied without the color-coded caps or nuts for manual welding applications.

For similar function studs, see Nelson [“W” Top Wide Flange studs](#), [ANC Unthreaded Stored Arc studs](#), [ATC Stored Arc studs](#), [CKL Collar studs](#), [AXC Fir Tree studs](#), and [“T” studs](#).

Grounding Studs

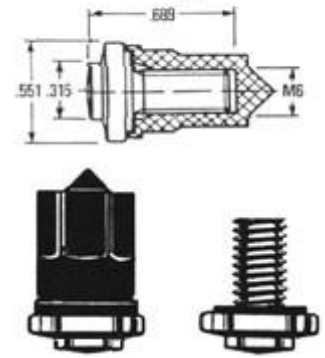

When ordering, specify: Type, Thread Size, Overall Length, Material, Plating, Quantity, Part Number
Example: GRD.STD Grounding Stud; M6 x 18mm; Mild Steel; Nickel Plated; 5,000 pieces; #101108638

Thread Type	D	L	C	Required Standard Accessory
				Chuck
M6	8	18	14	50000143
M8	8	18	14	50000143

MATERIALS: Nelson Grounding studs are available in Low Carbon Mild Steel with nickel plating, and 18-8 Stainless Steel. For specific grade information, physical and chemical properties, conforming standards, and information on stud plating and heat treating, please see [General Material Specifications](#).

THREADS: Standard external threads are 6g per ISO R261.

AUTO FEED: Studs to be used in automatic feed systems must be 100% sorted (Auto Feed quality). Therefore, “Auto Feed (AF) Quality” must be requested and specified at time of quotation and order entry. Please consult your Nelson Stud Welding sales representative regarding automatic feed accessories.

Studs

Automotive

NELSON STUD WELDING SPECIFICATION

H8X "T" Studs

Nelson "T" trim studs are welded to either bare or corrosion protection treated steel sheet metal for automotive applications. An extensive series of plastic and metal clips is available for use in conjunction with the "T" stud. The clips are retained by the head of the stud to perform a variety of functions, like retaining wires, tubes, hoses, trim strips, and even windows.

They are also used in the appliance and other sheet metal industries for similar applications. Due to the small size of these studs, Nelson "T" studs are normally welded using Nelson automatic feed stud welding systems.

New "T" stud sizes and shapes can be produced for specific requirements. Please see Nelson's [Cold Heading Compatibility Specifications](#) for additional information on cold-headed parts.

For similar function studs, see Nelson [ANC Unthreaded Stored Arc™ studs](#), [ATC Threaded Stored™ Arc studs](#), [AXC Fir Tree studs](#), ["W" Top Wide Flange studs](#), and [Grounding studs](#).

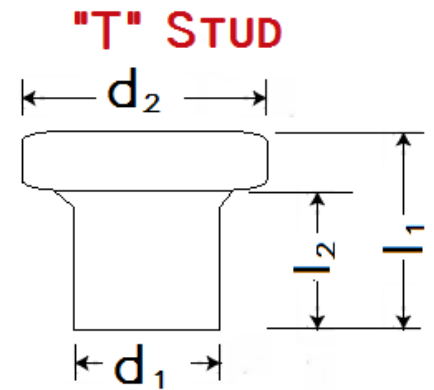

When ordering, specify: Type, Description, Material, Quantity, Part Number
Example: H8X T-stud 3.00mm x 4.00mm; Stainless Steel; 10,000 pieces; #101056001

D1	L1	D2	L2
3.00	4.00	5.05	3.00
3.00	4.15	5.05	3.00
3.00	5.40	5.05	4.35
5.00	10.00	9.00	8.20

MATERIALS: Studs are available in Low Carbon Mild Steel and 18-8 Stainless Steel. Copper plating is an available option for this stud. For specific grade information and physical and chemical properties, conforming standards, and information on stud plating and heat treating, please see [General Material Specifications](#).

Studs

Automotive

NELSON STUD WELDING SPECIFICATION

"W" Top Wide Flange Studs

Nelson "W" Top wide flange studs were developed for applications involving thin base material where full thread strength development was needed. Both metric and imperial thread versions of this stud are available for automotive and industrial customers.

These studs are welded using the Short Cycle weld process to thin sheet metal. The large diameter weld base provides increased weld area fusion to the base material. The wide flange isolates the assembly tension applied to the threads so that it cannot dimple or pull a hole in the base material.

The chamfer and dog point on the unwelded end of Nelson "W"-Top studs greatly facilitates rapid installation of nuts on the welded studs.

"W" Top studs can be automatically fed to Nelson rectifier powered welding guns, which may be hand held, press, or robotically manipulated, to weld the studs.

"W" Top studs are widely used in high volume automotive and appliance applications.

For similar function studs, see Nelson [Grounding studs](#), [ANC Unthreaded Stored Arc™ studs](#), [ATC Stored Arc™ studs](#), and [AXC "Fir Tree" type studs](#).

When ordering, specify: Type, Thread Size, Overall Length, Material, Plating, Quantity, Part Number

Example 1: "W"-Top 1/4-20 x 1-1/16"; Mild Steel; Copper Plated; 5,000 pieces; #101056077

Example 2: "W"-Top M6 x 20; Mild Steel; Clear Zinc Dichromate Plated; 5,000 pieces; #101056075

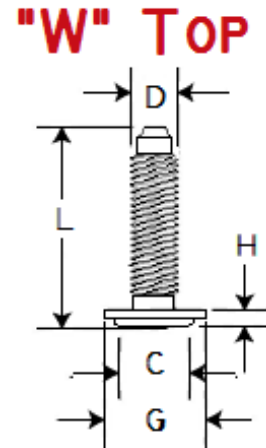

Thread Type	Weld base C	Thread Size D	Length L	Flange Diameter G	Flange Height H
1/4-20 x 3/4	0.354	1/4-20	3/4	13	2
1/4-20 x 1-1/16	0.354	1/4-20	1-1/16	13	2
M6 x 20 mm	9	M6	20	13	2
M6 x 25 mm	9	M6	25	13	2
M8 x 25 mm	9	M6	25	13	2

MATERIALS: Studs are available in Low Carbon Mild Steel and 18-8 Stainless Steel. For specific grade information, physical and chemical properties, conforming standards, and information on stud plating and heat treating, please see [General Material Specifications](#).

THREADS: Standard external threads are UNC-2A imperial or ISO R261, 6g metric.

Studs

Short Cycle / Stored Arc

NELSON STUD WELDING SPECIFICATION

ANC, ANS, and ANA Unthreaded Stored Arc Studs

Nelson ANC, ANS and ANA unthreaded studs are designed to be welded to thin gauge sheet metal using the Stored Arc method of stud welding, or a transformer/rectifier power-control source in the short-cycle mode. These applications generally provide a weld bond that is greater than the strength of the sheet to which they are welded.

Nelson Stored Arc studs have a flanged weld base that is about 1/32", or 1mm, greater than the nominal stud diameter. The "A" flange allows automatic stud feeding for increased production speeds. The flange also increases the stress area on the sheet. Standard studs come in lengths up to 1.25".

Unthreaded Stored Arc studs are commonly used as locator or stop points. They may also be tapped with internal threads, or have smaller diameter externally threaded extensions. Mild steel studs are copper flash plated, stainless studs are passivated, and aluminum studs are acid etched for superior weld results.

For similar function studs, see Nelson [ATC Threaded Stored Arc™ studs](#), [AXC "Fir Tree" studs](#), [Grounding studs](#), [H8X "T" studs](#), [TATC Auto-Feed Capacitor Discharge studs](#), [TFNC Flanged Capacitor Discharge studs](#), [TFTC Flanged Capacitor Discharge studs](#), [TUTC Unflanged Capacitor Discharge Studs](#), and ["W" Top Wide Flange studs](#).

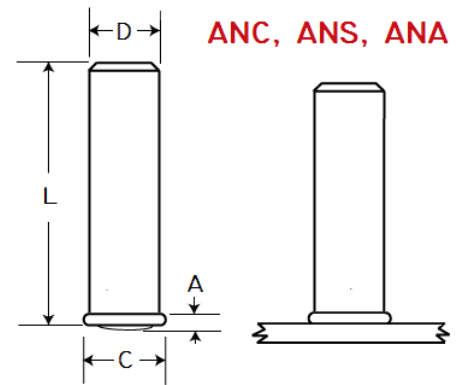

When ordering, specify: Type, Description, Material, Quantity, Part Number

Example: ANC 1/4 x 1/2"; Mild Steel; 10,000 pieces; #101211062

Stud Diameter D	Flange Thickness A		Flange Diameter C	Minimum Length L*	Required Standard Accessories		
	Steel	Aluminum			Chuck	Foot	Spark Shield
3/16	0.045	0.060	0.220	0.250	500001005	502001137	511001108
0.215	0.045	0.060	0.220	0.250	500001004	502001137	511001108
1/4	0.045	0.060	0.280	0.250	500001007	502001137	511001108
5/16	0.045	0.060	0.343	0.375	500001009	502001137	511001108

MATERIALS: Studs are available in Low Carbon Mild Steel with copper flash plate (ANC), 18-8 Stainless Steel (ANS), and 1100 Aluminum (ANA). Some materials may be available by special order. For specific grade information and physical and chemical properties, conforming standards, and information on stud plating and heat treating, please see [General Material Specifications](#).

***AUTO FEED:** For automatic feed applications, stud length must be a minimum of 1-1/2 times the flange diameter. Studs to be used in automatic feed systems must be 100% sorted (Auto Feed quality). Therefore, "Auto Feed (AF) Quality" must be requested and specified at time of quotation and order entry.

Studs

Short Cycle / Stored Arc

NELSON STUD WELDING SPECIFICATION

ATC, ATS, and ATA Threaded Stored Arc Studs

Stored Arc ATC, ATS, and ATA studs are designed to be welded to thin gauge sheet metal using either the Stored Arc method of stud welding, or a transformer/rectifier power-control source in the short-cycle mode. These applications generally provide a weld bond that is greater than the strength of the sheet to which they are welded.

Nelson Stored Arc studs have a flanged weld base that is about 1/32", or 1mm, greater than the nominal stud diameter. The "A" flange allows automatic stud feeding for increased production speeds. The flange also increases the stress area on the sheet. Standard studs are fully threaded, and come in lengths up to 1.25".

Mild steel studs are copper flash plated, stainless studs are passivated, and aluminum studs are acid etched for superior weld results.

For similar function studs, see Nelson [ANC Unthreaded Stored Arc™ studs](#), [AXC "Fir Tree" studs](#), [Grounding studs](#), [H8X "T" studs](#), [TATC Auto-Feed Capacitor Discharge studs](#), and ["W" Top Wide Flangestuds](#).

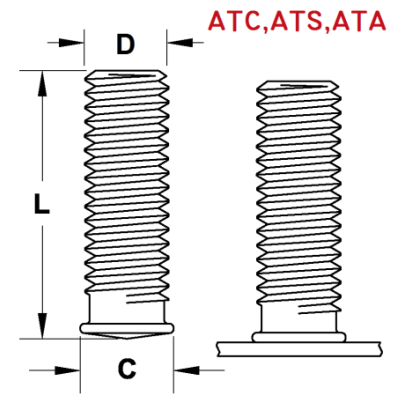

When ordering, specify: Type, Description, Material, Quantity, Part Number

Example: ATC 1/4-20 x 3/4"; Mild Steel; 10,000 pieces; #101228039

Thread Size	Stud Diameter D	Flange Diameter C	Minimum Length L*	Required Standard Accessories		
				Chuck	Foot	Spark Shield
#6-32	0.138	0.168	0.250	500001002	502001137	511001108
#8-32	0.164	0.194	0.250	500001006	502001137	511001108
#10-24	0.187	0.220	0.250	500001005	502001137	511001108
#10-32	0.187	0.220	0.250	500001005	502001137	511001108
1/4-20	0.250	0.280	0.250	500001007	502001137	511001108
5/16-18	0.312	0.343	0.375	500001009	502001137	511001108

MATERIALS: Studs are available in Low Carbon Mild Steel (ATC), Stainless Steel (ATS), and 1100 Aluminum (ATA). Some materials may be available by special order. For specific grade information and physical and chemical properties, conforming standards, and information on stud plating and heat treating, please see [General Material Specifications](#).

THREADS: Standard external threads are UNC-2A, or UNF-2A for #10-32.

***AUTO FEED:** For automatic feed applications, stud length must be a minimum of 1-1/2 times the flange diameter. Studs to be used in automatic feed systems must be 100% sorted (Auto Feed quality). Therefore, "Auto Feed (AF) Quality" must be requested and specified at time of quotation and order entry.

Studs

Metric Short Cycle / Stored Arc

NELSON STUD WELDING SPECIFICATION

ATC, ATS, and ATA Threaded Studs

Nelson metric Stored Arc ATC, ATS, and ATA studs are designed to be welded to thin gauge sheet metal using either the Stored-Arc method of stud welding, or a transformer/ rectifier power-control source in the short-cycle mode. These applications generally provide a weld bond that is greater than the strength of the sheet to which they are welded.

Nelson Stored Arc studs have a flanged weld base that is about 1mm greater than the nominal stud diameter. The mini flange diameter "C" allows automatic stud feeding for increased production speeds. The flange also increases the stress area on the sheet. Standard studs are fully threaded, and come in lengths up to 32mm.

Mild steel studs are copper flash plated, stainless studs are passivated, and aluminum studs are acid etched for superior weld results.

For similar function metric studs, see Nelson [ANC Unthreaded Stored Arc™ studs](#), [AXC "Fir Tree" studs](#), [Grounding studs](#), [H8X "T" studs](#), and ["W" Top Wide Flange studs](#). In the imperial line of Nelson studs, see [TATC Auto-Feed Capacitor Discharge studs](#).

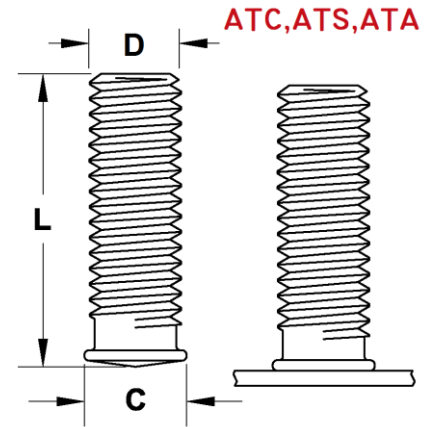

When ordering, specify: Type, Description, Material, Quantity, Part Number

Example: ATC M6 x 16mm; Mild Steel; 10,000 pieces; #101228124

Thread Size	Stud Diameter D	Flange Diameter C	Minimum Length L*	Required Standard Accessories		
				Chuck	Foot	Spark Shield
M3 x 0.50	3.00	4	8.00	500001135	502001137	511001108
M4 x 0.70	4.00	5	8.00	500001003	502001137	511001108
M5 x 0.80	5.00	6	8.00	500001005	502001137	511001108
M6 x 1.00	6.00	7	10.00	500001267	502001137	511001108
M8 x 1.25	8.00	9	12.00	500001009	502001137	511001108

MATERIALS: Studs are available in Low Carbon Mild Steel (ATC), Stainless Steel (ATS), and 1100 Aluminum (ATA). Some materials may be available by special order. For specific grade information and physical and chemical properties, conforming standards, and information on stud plating, please see [General Material Specifications](#).

THREADS: Standard metric threads meet ISO 6g.

***AUTO FEED:** For automatic feed applications, stud length must be a minimum of 1-1/2 times the flange diameter. Studs to be used in automatic feed systems must be 100% sorted (Auto Feed quality). Therefore, "Auto Feed (AF) Quality" must be requested and specified at time of quotation and order entry.

Studs

Metric Short Cycle / Stored Arc

NELSON STUD WELDING SPECIFICATION

ANC, ANS, and ANA Unthreaded Studs

Metric Nelson ANC, ANS and ANA unthreaded studs are designed to be welded to thin gauge sheet metal using the Stored Arc method of stud welding, or a transformer/rectifier power-control source in the short-cycle mode. These applications generally provide a weld bond that is greater than the strength of the sheet to which they are welded.

Nelson Stored Arc studs have a flanged weld base that is 1mm greater than the nominal stud diameter. The mini flange diameter "C" allows automatic stud feeding for increased production speeds. The flange also increases the stress area on the sheet. Standard studs come in lengths up to 30mm.

Unthreaded Stored Arc studs are commonly used as locator or stop points. They may also be tapped with internal threads, or have smaller diameter externally threaded extensions. They also may have Speed Clips or self-threading nuts installed on them, and can be made with special chamfers to aid in the installation of such clips or nuts.

Mild steel studs are copper flash plated, stainless studs are passivated, and aluminum studs are acid etched to assure superior weld results.

For similar function metric studs, see Nelson [ATC Threaded Stored Arc™ studs](#), [AXC "Fir Tree" studs](#), [Grounding studs](#), [H8X "T" studs](#), and ["W" Top Wide Flange studs](#). In the imperial line of Nelson studs, see [TATC Auto-Feed Capacitor Discharge studs](#), [TFNC Flanged Capacitor Discharge studs](#), [TFTC Flanged Capacitor Discharge studs](#), and [TUTC Unflanged Capacitor Discharge Studs](#).

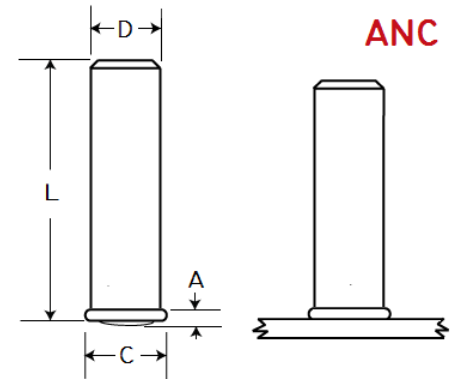

When ordering, specify: Type, Description, Material, Quantity, Part Number

Example: ANC M4 x 8.25mm; Mild Steel; 10,000 pieces; #101211133

Stud Diameter D	Flange Thickness A	Flange Diameter C	Minimum Length L*	Required Standard Accessories		
				Chuck	Foot	Spark Shield
3.00	0.75	4.00	8.00	500001135	502001137	511001108
4.00	0.90	5.00	8.00	500001003	501001137	511001108
5.00	1.10	6.00	8.00	500001427	502001137	511001108
6.00	1.30	7.00	10.00	500001267	502001137	511001108
8.00	1.65	9.00	12.00	500001009	502001137	511001108

MATERIALS: Studs are available in Low Carbon Mild Steel with copper flash plate (ANC), 18-8 Stainless Steel (ANS), and 1100 Aluminum (ANA). Some materials may be available by special order. For specific grade information and physical and chemical properties, conforming standards, and information on stud plating, please see [General Material Specifications](#).

***AUTO FEED:** For automatic feed applications, stud length must be a minimum of 1-1/2 times the flange diameter. Studs to be used in automatic feed systems must be 100% sorted (Auto Feed quality). Therefore, "Auto Feed (AF) Quality" must be requested and specified at time of quotation and order entry.

Studs

Capacitor Discharge

NELSON STUD WELDING SPECIFICATION

TATC, TATS, TATA Auto-Feed Threaded Capacitor Discharge Studs

These studs are designed to be welded to thin gauge sheet material by the initial “gap” or “contact” method of stud welding using tip ignition according to the capacitor discharge (CD) process. These applications generally provide a weld bond whose strength is greater than that of the base material to which they are welded.

These studs have a special flanged weld base that is about 1/32”, or 1mm, greater than the nominal stud diameter. The mini flange diameter “C” allows automatic stud feeding for increased production speeds. The flange also increases the stress area welded to the base material. These Nelson studs are fully threaded, and come in lengths up to 1.25”.

Whereas these studs are designated as auto-feed studs, they are manual feed capable. Shown below is the equipment required for manual loading of TATC, TATS, and TATA studs.

For similar function studs, see Nelson [ANC Unthreaded Stored Arc™ studs](#), [ATC Threaded Stored Arc™ studs](#), and [AXC “Fir Tree” studs](#).

TATC, TATS, TATA

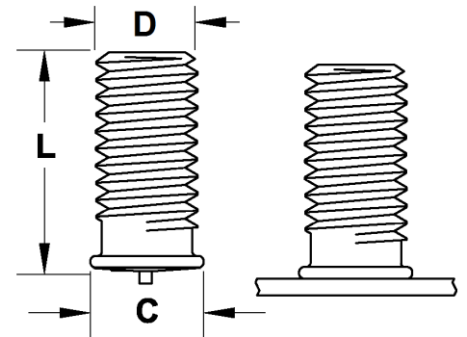

When ordering, specify: Type, Description, Material, Quantity, Part Number
Example: TATC #10-32 x 5/16”; Mild Steel; 10,000 pieces; #101218258

Thread Size	Stud Diameter D	Flange Diameter C	Minimum Length L	Required Standard Accessories	
				Chuck* Series 650 Style Gun	Chuck Assembly CD-Lite Gun
#4-40	0.112	0.142	0.250	500001355	521322
#6-32	0.138	0.168	0.250	500001356	521323
#8-32	0.164	0.194	0.250	500001357	215502
#10-24	0.187	0.220	0.250	500001358	215503
#10-32	0.187	0.220	0.250	500001358	215503
1/4-20	0.250	0.280	0.250	500001359	215504
5/16-18	0.312	0.355	0.375	500001360	520327
3/8-16	0.375	0.418	0.375	500001369	N/A

* A backup pin or stud stop is required for use with these chucks. The list below shows part numbers and corresponding stud lengths for each pin length.

Back-up Pin Part Number	For Stud Lengths (inches)
500017017	1/4 to 5/8
500017018	3/4 to 1-1/8
500017019	1-1/4 to 1-5/8
500017020	1-3/4 to 2-1/8

MATERIALS: Studs are available in Low Carbon Mild Steel (TFTC), 18-8 Stainless Steel (TFTS), and 6061 Aluminum (TFTA). Some materials may be available by special order. For specific grade information and physical and chemical properties, conforming standards, and information on stud plating, please see [General Material Specifications](#).

THREADS: Standard external threads are typically UNC-2A, or UNF-2A for #10-32.

Studs

Capacitor Discharge

NELSON STUD WELDING SPECIFICATION

TFNC, TFNS, and TFNA Flanged Unthreaded Capacitor Discharge Studs

These unthreaded studs are designed to be welded to thin sheet material by the initial “gap” or “contact” method of stud welding using tip ignition according to the capacitor discharge (CD) weld process. These applications generally provide a weld bond strength that is greater than the strength of the thin base material to which they are welded.

Flanged unthreaded capacitor discharge studs are commonly used as locator or stop points. They may also be tapped with internal threads, or have smaller diameter externally threaded extensions

These studs have a flanged weld base that is about 1/16” greater than the nominal stud diameter. The flange increases the weld bond area for greater reliability.

For superior welding results, mild steel studs are copper flash plated, stainless studs are passivated, and aluminum studs are acid etched.

TFNC, TFNS, TFNA

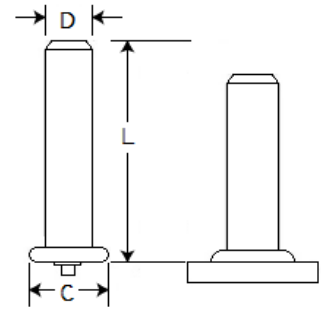

For similar function studs, see Nelson [ANC Unthreaded Stored Arc™ studs](#) and [AXC “Fir Tree” studs](#).

When ordering, specify: Type, Description, Material, Quantity, Part Number

Example: TFNC 3/16 x 1-1/2”; Mild Steel; 10,000 pieces; #101218902

Stud Diameter D	Flange Diameter C	Minimum Length L	Required Standard Accessories	
			Chuck* Series 650 Style Gun	Chuck Assembly CD-Lite Gun
3/16	0.250	0.250	500001358	215503
1/4	0.312	0.250	500001359	215504
5/16	0.437	0.375	500001360	520327

* A backup pin or stud stop is required for use with these chucks. The list below shows part numbers and corresponding stud lengths for each pin length.

Back-up Pin Part Number	For Stud Lengths (inches)
500017017	1/4 to 5/8
500017018	3/4 to 1-1/8
500017019	1-1/4 to 1-5/8
500017020	1-3/4 to 2-1/8

MATERIALS: Studs are available in Low Carbon Mild Steel (TFTC), 18-8 Stainless Steel (TFTS), and 6061 Aluminum (TFTA). Some materials may be available by special order. For specific grade information and physical and chemical properties, conforming standards, and information on stud plating, please see [General Material Specifications](#).

THREADS: Standard external threads are typically UNC-2A, or UNF-2A for #10-32.

Studs

Capacitor Discharge

NELSON STUD WELDING SPECIFICATION

TFTC, TFTS, and TFTA Flanged Threaded Capacitor Discharge Studs

These studs are designed to be welded to thin sheet material by the initial “gap” or “contact” method of stud welding using tip ignition according to the capacitor weld discharge process. These applications generally provide a weld bond strength that is greater than the strength of the thin base material to which they are welded.

These studs have a flanged weld base that is about 1/16” greater than the nominal stud diameter. The studs are fully threaded, and come in lengths up to two inches.

For similar function studs, see Nelson [ANC Unthreaded Stored Arc™ studs](#) and [AXC “Fir Tree” studs](#).

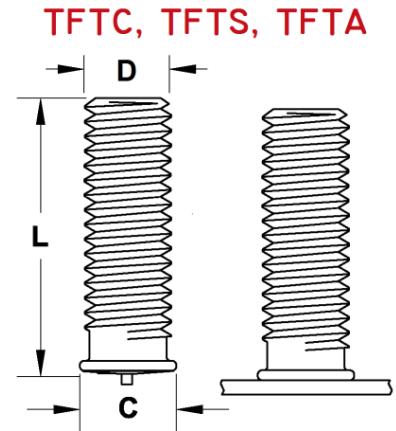

When ordering, specify: Type, Description, Material, Quantity, Part Number
Example: TFTC 10-24 x 1”; Mild Steel; 10,000 pieces; #101208250

Thread Size	Stud Diameter D	Flange Diameter C	Minimum Length L	Required Standard Accessories	
				Chuck* Series 650 Style Gun	Chuck Assembly CD-Lite Gun
#4-40	0.112	0.187	0.250	500001355	521322
#6-32	0.138	0.218	0.250	500001356	521323
#8-32	0.164	0.250	0.250	500001357	215502
#10-24	0.187	0.250	0.250	500001366	215503
#10-32	0.187	0.250	0.250	500001366	215503
1/4-20	0.250	0.312	0.250	500001359	215504
5/16-18	0.312	0.375	0.375	500001360	520327
3/8-16	0.375	0.437	0.375	500001369	N/A

* A backup pin or stud stop is required for use with these chucks. The list below shows part numbers and corresponding stud lengths for each pin length.

Back-up Pin Part Number	For Stud Lengths (inches)
500017017	1/4 to 5/8
500017018	3/4 to 1-1/8
500017019	1-1/4 to 1-5/8
500017020	1-3/4 to 2-1/8

MATERIALS: Studs are available in Low Carbon Mild Steel (TFTC), 18-8 Stainless Steel (TFTS), and 6061 Aluminum (TFTA). Some materials may be available by special order. For specific grade information and physical and chemical properties, conforming standards, and information on stud plating, please see [General Material Specifications](#).

THREADS: Standard external threads are typically UNC-2A, or UNF-2A for #10-32.

Studs

Capacitor Discharge

NELSON STUD WELDING SPECIFICATION

TUTC, TUTS, and TUTA Unflanged Threaded Capacitor Discharge Studs

These unflanged studs are designed to be welded to thin sheet material by the initial “gap” or “contact” method of stud welding using tip ignition according to the capacitor discharge process. These applications generally provide a weld bond whose strength is sufficient for the application when considering the strength of the sheet to which they are welded.

These studs have a flanged weld base which is about the same as the stud diameter. The unflanged studs are used where weld fillet control is more important than weld strength and reliability. The studs are fully threaded, and come in lengths up to 2”.

TUTC, TUTS, TUTA

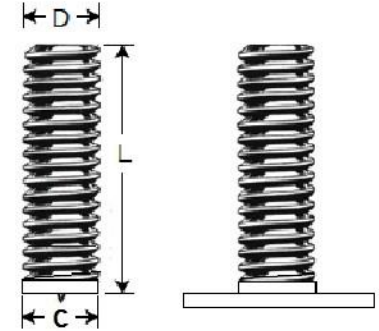

For similar function, see Nelson [ANC Unthreaded Stored Arc studs](#) and [AXC “Fir Tree” studs](#).

When ordering, specify: Type, Description, Material, Quantity, Part Number

Example: TUTC #4-40 x 1/2”; Mild Steel; 10,000 pieces; #101208604

Thread Size	Stud Diameter D	Flange Diameter C	Minimum Length L	Required Standard Accessories	
				Chuck* Series 650 Style Gun	Chuck Assembly CD-Lite Gun
#4-40	0.112	0.111	0.250	500001355	521322
#6-32	0.138	0.137	0.250	500001356	521323
#8-32	0.164	0.163	0.250	500001357	215502
#10-24	0.187	0.189	0.250	500001366	215503
#10-32	0.187	0.189	0.250	500001366	215503
1/4-20	0.250	0.250	0.250	500001359	215504
5/16-18	0.312	0.312	0.375	500001360	520327
3/8-16	0.375	0.375	0.375	500001369	N/A

* A backup pin or stud stop is required for use with these chucks. The list below shows part numbers and corresponding stud lengths for each pin length.

Back-up Pin Part Number	For Stud Lengths (inches)
500017017	1/4 to 5/8
500017018	3/4 to 1-1/8
500017019	1-1/4 to 1-5/8
500017020	1-3/4 to 2-1/8

MATERIALS: Studs are available in Low Carbon Mild Steel (TUTC), 18-8 Stainless Steel (TUTS), and 6061 Aluminum (TUTA). Some materials may be available by special order. For specific grade information and physical and chemical properties, conforming standards, and information on stud plating, please see [General Material Specifications](#).

THREADS: Standard external threads are typically UNC-2A, or UNF-2A for #10-32.

Studs

Metric Capacitor Discharge

NELSON STUD WELDING SPECIFICATION

TFNC, TFNS, TFNA Flanged Unthreaded Studs

These unthreaded metric studs are designed to be welded to thin sheet material by the initial “gap” or “contact” method of stud welding using tip ignition capacitor discharge weld process. These applications generally provide a weld bond strength that is greater than the strength of the thin base material to which they are welded.

These studs have a flanged weld base that is about 2mm greater than the nominal stud diameter. The studs are fully threaded, and come in lengths up to 50mm.

For similar function studs, see Nelson [ANC Unthreaded Stored Arc™ studs](#) and [TPC Tipped Insulation pins](#). In the imperial line of Nelson studs, see [TATC Auto-Feed Capacitor Discharge studs](#) and [TFNC Flanged Unthreaded Capacitor Discharge studs](#).

TFNC, TFNS, TFNA

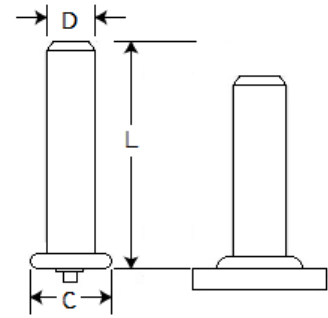

When ordering, specify: Type, Description, Material, Quantity, Part Number

Example: TFNC 10-24 x 1"; Mild Steel; 10,000 pieces; #101208250

Stud Diameter D	Flange Diameter C	Minimum Length L	Required Standard Accessories	
			Chuck* Series 650 Style Gun	Chuck Assembly CD-Lite Gun
3.00	5.00	6.00	500001355	215500
4.00	6.00	6.00	500001361	215501
5.00	7.00	6.00	500001358	215502
6.00	8.00	8.00	500001362	215503
8.00	10.50	10.00	500001360	250104

* A backup pin or stud stop is required for use with these chucks. The list below shows part numbers and corresponding stud lengths for each pin length.

Back-up Pin Part Number	For Stud Lengths (millimeters)
500017017	6 – 16
500017018	20 – 30
500017019	32 – 40
500017020	45 – 55

MATERIALS: Studs are available in Low Carbon Mild Steel (TFTC), 18-8 Stainless Steel (TFTS), and 6061 Aluminum (TFTA). Some materials may be available by special order. For specific grade information and physical and chemical properties, conforming standards, and information on stud plating, please see [General Material Specifications](#).

THREADS: Standard external metric threads meet ISO 6g.

Studs

Metric Capacitor Discharge

NELSON STUD WELDING SPECIFICATION

TFTC, TFTS, TFTA Flanged Threaded CD Studs

These threaded metric studs are designed to be welded to thin sheet material by the initial “gap” or “contact” method of stud welding using tip ignition capacitor weld discharge process. These applications generally provide a weld bond strength that is greater than the strength of the thin base material to which they are welded.

These studs have a flanged weld base that is about 2mm greater than the nominal stud diameter. The studs are fully threaded, and come in lengths up to 50mm.

For similar function studs, see Nelson [ANC Unthreaded Stored Arc studs](#) and [TPC Tipped Insulation pins](#). In the imperial line of Nelson Studs, see [TATC Auto-Feed Capacitor Discharge studs](#) and [TFNC Flanged Unthreaded Capacitor Discharge studs](#).

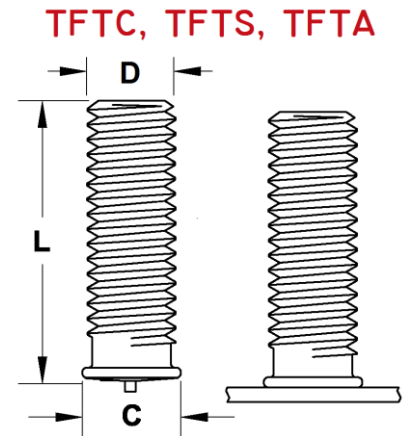

When ordering, specify: Type, Description, Material, Quantity, Part Number

Example: TFTC M4 x 16mm; Mild Steel; 10,000 pieces; #101217117

Thread Size D	Stud Diameter D	Flange Diameter C	Flange Thickness	Minimum Length L	Required Standard Accessories	
					Chuck* Series 650 Style Gun	Chuck Assembly CD-Lite Gun
M3 x 0.50	3.00	5.00	0.9	6.00	500001355	215500
M4 x 0.70	4.00	6.00	0.9	6.00	500001361	215501
M5 x 0.80	5.00	7.00	1.0	6.00	500001358	215502
M6 x 1.00	6.00	8.00	1.2	8.00	500001362	215503
M8 x 1.25	8.00	10.50	1.3	10.00	500001360	250104

* A backup pin or stud stop is required for use with these chucks. The list below shows part numbers and corresponding stud lengths for each pin length.

Back-up Pin Part Number	For Stud Lengths (millimeters)
500017017	6 – 16
500017018	20 – 30
500017019	32 – 40
500017020	45 – 55

MATERIALS: Studs are available in Low Carbon Mild Steel (TFTC), 18-8 Stainless Steel (TFTS), and 6061 Aluminum (TFTA). Some materials may be available by special order. For specific grade information and physical and chemical properties, conforming standards, and information on stud plating, please see [General Material Specifications](#).

THREADS: Standard external metric threads meet ISO 6g.

Studs

Aluminum Drawn Arc

NELSON STUD WELDING SPECIFICATION

HBA Full Base Threaded Aluminum Studs

Nelson HBA threaded aluminum studs are available in thread sizes of #10-24 through 1/2-13. They are used for attaching parts to aluminum structures. They are welded using ceramic ferrules in conjunction with argon as a shielding gas. The full nominal weld base for the HBA studs gives greater weld reliability and strength than could be achieved using a pitch diameter weld base.

The shielding gas is introduced to the weld area through a gas foot assembly, #751020000, which is used for all diameters of HBA studs. Gas hose #515001001 and gas regulator #514001001 are needed to deliver and control the gas flow from a pressurized cylinder.

An aluminum Tranquil-Arc™ plunge dampener kit is also needed as an accessory on the gun to control the rate of the stud's return in to the molten weld metal at the end of the weld cycle.

For similar function, please refer to Nelson [NBA Unthreaded Aluminum studs](#) and [TBA Internally Threaded Aluminum studs](#).

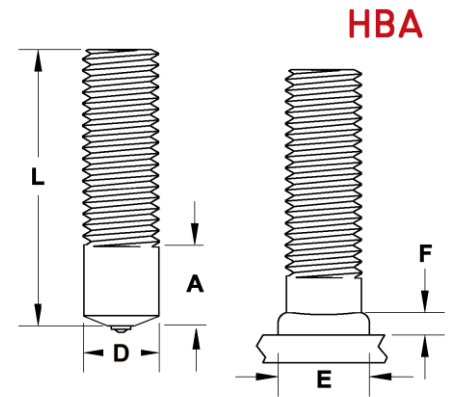

When ordering, specify: Type, Diameter, Before Weld Length, Material, Quantity, Part Number

Example: HBA 3/8-16 x 2-1/2"; Aluminum; 10,000 pieces; #101044056

Thread Size	Stud Diameter	Minimum Unthreaded	Minimum Stud Length	Weld Flash Size		Burn Off	Flash Clearance	Required Standard Accessories	
	D	A	L	E	F			Ferrule	Chuck
#10-24	3/16	0.312	0.812	0.330	0.125	0.093	0.390	100101046	500001005
1/4-20	1/4	0.312	0.937	0.406	0.125	0.093	0.469	100101047	500001007
5/16-18	5/16	0.343	0.937	0.468	0.156	0.093	0.531	100101048	500001009
3/8-16	3/8	0.390	0.937	0.603	0.187	0.093	0.656	100101049	500001011
7/16-14	7/16	0.468	0.937	0.656	0.218	0.093	0.750	100101050	500001012
1/2-13	1/2	0.515	0.937	0.750	0.250	0.125	0.843	100101051	500001014

MATERIALS: HBA Studs are only available in 5356 Aluminum. The maximum length of useable thread on all HBA aluminum studs is 1- 1/4". For specific grade information and physical and chemical properties, conforming standards, and information on heat treating, please see [General Material Specifications](#).

THREADS: Standard external threads are UNC-2A.

Studs

Aluminum Drawn Arc

NELSON STUD WELDING SPECIFICATION

CKA Aluminum Collar Studs

Nelson CKA aluminum collar studs are available in thread sizes of 1/4-20 through 1/2-13. They are used for attaching parts to aluminum structures. They are welded using ceramic ferrules in conjunction with argon as a shielding gas. The collar on CKL studs is useful in mounting applications where a standoff is needed.

The shielding gas is introduced to the weld area through a gas foot assembly, #751020000, which is used for all diameters of CKA studs. Gas hose #515001001 and gas regulator #514001001 are needed to deliver and control the gas flow from a pressurized cylinder.

An aluminum Tranquil-Arc™ plunge dampener kit is also needed as an accessory on the gun to control the rate of the stud's return in to the molten weld metal at the end of the weld cycle.

Studs are available in before weld lengths greater than the specified minimum length to a maximum of 4-1/8".

For similar function studs, please refer to Nelson [HBA Threaded Full Base studs](#) and [TBA Internally Threaded studs](#).

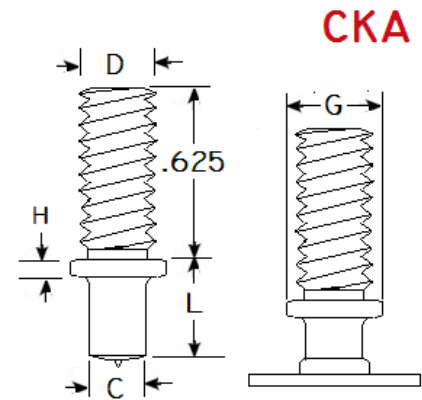

When ordering, specify: Type, Base Diameter, Base Length, Thread Size, Extension Length, Material, Quantity, Part Number

Example: CKA 0.330 x 1.125, 3/8-16 x 3/4"; Aluminum; 10,000 pieces; #101015642

Thread Size	Stud Diameter D	Weld Base C	Minimum Stud Length L	G	H	Burn Off	Flash Clearance	Required Standard Accessories	
								Ferrule	Chuck
1/4-20	1/4	0.215	0.500	0.500	0.093	0.125	0.469	100101047	500001007
5/16-18	5/16	0.275	0.500	0.562	0.093	0.156	0.531	100101048	500001009
3/8-16	3/8	0.330	0.625	0.625	0.093	0.187	0.656	100101049	500001011
7/16-14	7/16	0.387	0.625	0.750	0.093	0.218	0.750	100101050	500001012
1/2-13	1/2	0.448	0.625	0.750	0.093	0.250	0.843	100101051	500001014

MATERIALS: CKA Studs are available in 5356-H32 Aluminum. For specific grade information and physical and chemical properties, as well as information on heat treating, please see [General Material Specifications](#).

THREADS: Standard external threads are UNC-2A.

Studs

Aluminum Drawn Arc

NELSON STUD WELDING SPECIFICATION

NBA Unthreaded Aluminum Studs

Nelson NBA unthreaded aluminum studs are available in diameters of 3/16" through 1/2". They are used as mounting, pivot, and stop pins on aluminum structures. They are welded using ceramic ferrules in conjunction with argon as a shielding gas.

The shielding gas is introduced to the weld area through a gas foot assembly, #751020000, which is used for all diameters of NBA studs. Gas hose #515001001 and gas regulator #514001001 are needed to deliver and control the gas flow from a pressurized cylinder.

An aluminum Tranquil-Arc™ plunge dampener kit is also needed as an accessory on the gun to control the rate of the stud's return in to the molten weld metal at the end of the weld cycle.

For similar function, please refer to Nelson [HBA Threaded Aluminum studs](#) and [TBA Internally Threaded studs](#).

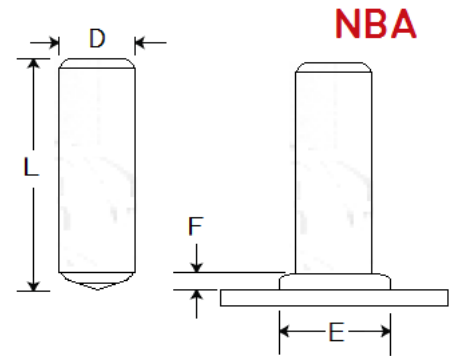

When ordering, specify: Type, Diameter, Before Weld Length, Material, Quantity, Part Number

Example: NBA 1/2 x 3"; Mild Steel; 10,000 pieces; #101074014

Stud D	Minimum Stud L	Burn Off	Weld Flash Size		Flash Clearance	Required Standard Accessories	
			E	F		Ferrule	Chuck
3/16	0.812	0.093	0.330	0.125	0.390	100101046	500001005
1/4	0.937	0.093	0.406	0.125	0.469	100101047	500001007
5/16	0.937	0.093	0.468	0.156	0.531	100101048	500001009
3/8	0.937	0.093	0.603	0.187	0.656	100101049	500001011
7/16	0.937	0.093	0.656	0.218	0.750	100101050	500001012
1/2	0.937	0.125	0.750	0.250	0.843	100101051	500001014

MATERIALS: NBA Studs are only available in Aluminum. For specific grade information and physical and chemical properties, as well as information on heat treating, please see [General Material Specifications](#).

Studs

Aluminum Drawn Arc

NELSON STUD WELDING SPECIFICATION

SBA Threaded Aluminum Shoulder Studs

Nelson SBA shoulder studs have a weld base diameter larger than the threaded extension diameter. They are available in weld base diameters 1/4" through 1/2", with threaded extension sizes up to 7/16-14.

The Nelson SBA studs are used as mountings for panels and hardware where a standoff shoulder is needed. SBA studs are similar to CKA aluminum collar studs, but the larger weld base provides improved bend resistance.

Both chuck size and part numbers are determined by the thread size, C. Please refer to the Nelson [HBA stud specification sheet](#) to find the appropriate chuck size and number.

Nelson SBA studs are welded using ceramic ferrules in conjunction with argon as a shielding gas. The shielding gas is introduced through a gas foot assembly, #751020000, which is used for all diameters of SBA studs. Gas hose #515001001 and a gas regulator #514001001 are needed to deliver and control the gas flow from a pressurized cylinder.

An aluminum Tranquil-Arc plunge dampener kit is also needed as an accessory on the gun to control the rate of the stud's return to the molten weld metal at the end of the weld cycle.

For similar function aluminum studs, please refer to Nelson [CKA Threaded Aluminum Collar studs](#), [HBA Threaded Full Base studs](#), and [TBL Internally Threaded studs](#).

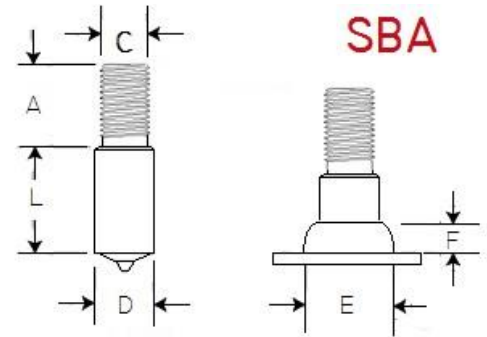

When ordering, specify: Type, Base Diameter, Base Length, Thread Size, Extension Thread Size, Extension Length, Material, Quantity, Part Number

Example: SBA 1/2 x 1; 3/8-16 x 3/4"; Aluminum; 10,000 pieces; #101093660

Major Diameter D	Maximum Thread Diameter C	Standard Maximum Length A	Minimum Length L	Weld Flash Dimensions		Required Standard Accessories		
				E	F	Ferrule	Grip	Foot
1/4	#10-24	0.468	0.312	0.406	0.125	100101047	501001007	500001007
5/16	1/4-20	0.635	0.343	0.468	0.156	100101048	501001006	500001009
3/8	5/16-18	0.781	0.390	0.603	0.187	100101049	501001009	500001011
7/16	3/8-16	0.937	0.468	0.656	0.218	100101050	501001008	500001012
1/2	7/16-14	0.937	0.500	0.750	0.250	100101151	501001011	500001014

MATERIALS: Studs are available in 5356 Aluminum. Material selection is dependent on anticipated service temperature range. For specific grade information and physical and chemical properties, conforming standards, and information on heat treating, please see [General Material Specifications](#).

THREADS: Standard external threads are UNC-2A.

Studs

Aluminum Drawn Arc

NELSON STUD WELDING SPECIFICATION

TBA Internally Threaded Aluminum Studs

Nelson TBA internally threaded aluminum studs are available with weld base diameters of 1/4" through 1/2", with thread sizes of #10-24 through 1/2-13. They are used as mounting points on aluminum structures. They are welded using ceramic ferrules in conjunction with argon as a shielding gas.

The shielding gas is introduced to the weld area through a gas foot assembly, #751020000, which is used for all diameters of TBA studs. Gas hose #515001001 and gas regulator #514001001 are needed to deliver and control the gas flow from a pressurized cylinder.

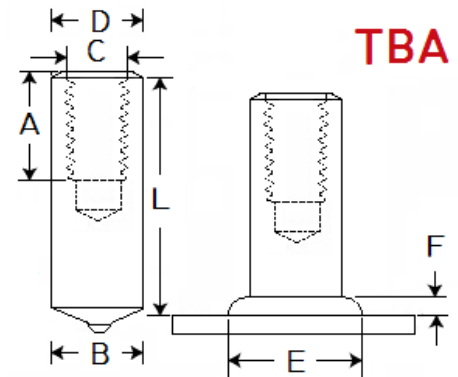

An aluminum Tranquil-Arc™ plunge dampener kit is also needed as an accessory on the gun to control the rate of the stud's return in to the molten weld metal at the end of the weld cycle.

The minimum length of Nelson TBA studs, shown below, is the before weld length of the stud, and is dependent on the thread depth.

For similar function aluminum studs, please refer to Nelson [HBA Externally Threaded Aluminum studs](#), [SBA Aluminum Shoulder studs](#), and [CKA Aluminum Collar studs](#).

When ordering, specify: Type, Diameter, Before Weld Length, Tap Size, Tap Depth, Material, Quantity, Part Number

Example: TBA 1/2 x 1"; tap 3/8-16 x 9/16"; 5356 Aluminum; 10,000 pieces; #10108478

Stud Diameter D	Maximum Tap Diameter C	Minimum Stud Length, L		Weld Base Diameter B	Burn Off	Weld Flash Size		Flash Clearance	Required Standard Accessories	
		D = 1/2 max	D = 5/8 & 3/4			E	F		Ferrule	Chuck
1/4	10-24	0.93	N	1/4	0.093	0.406	0.125	0.469	100101047	500001007
5/16	1/4-20	1.06	1	5/16	0.093	0.468	0.156	0.531	100101048	500001009
3/8	5/16-18	1.18	1	3/18	0.093	0.603	0.187	0.656	100101049	500001011
7/16	3/8-16	1.31	1	7/16	0.093	0.656	0.218	0.750	100101050	500001012
1/2	7/16-14	N/A	1	1/2	0.125	0.750	0.250	0.843	100101051	500001014
5/8	1/2-13	N/A	2	1/2	0.125	0.750	0.250	0.843	100101051	500001016
3/4	1/2-13	N/A	2	1/2	0.125	0.750	0.250	0.843	100101051	500001018

MATERIALS: TBA Studs are only available in Aluminum. For specific grade information and physical and chemical properties, as well as information on heat treating, please see [General Material Specifications](#).

THREADS: Standard depth of useable threads, A, is 1-1/2 times the tap diameter. All internal threads are UNC-2B.

Studs

Aluminum Drawn Arc

NELSON STUD WELDING SPECIFICATION

N3A Aluminum Navy Type Annular Pins

N3A Navy pins are welded for the attachment of insulation. The insulation is impaled over the welded studs and retained with caps that are driven onto the studs, and lock onto the annular rings. The 5/16" diameter welded end on Nelson N3A pins permits welding without the use of inert gas shielding, which is normally required when welding aluminum studs.

The flat top caps for use with N3A studs are usually supplied in aluminum. They can also be supplied in plated mild steel or stainless steel, per the [N3P Annular Ring stud](#). The standard N3A cap is shown below and is supplied in aluminum.

For similar function studs, see Nelson [N3P Annular Ring Navy Pin](#), [P2P Double Pointed Insulation Pins](#), [TPC Single Pointed Insulation Pins](#), and [CHP Cupped Headed Insulation Pins](#).

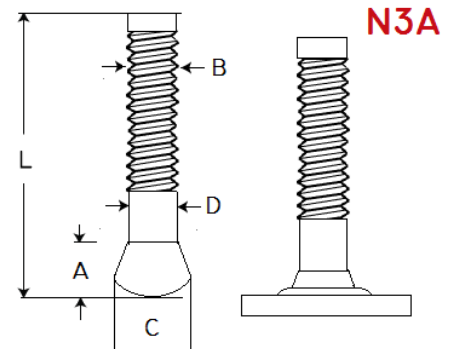

When ordering, specify: Type, Description, Material, Quantity, Part Number
 Example: N3A 3/16 x 1"; Mild Steel; 10,000 pieces; #101074014

Stud Description	Minimum Length L	D	A	B	C	Required Standard Accessories			
						Ferrule	Chuck	Grip	Foot
3/16 x L	1.000	0.178	0.250	0.176	0.312	100101007	500001005	501001006	502001137

MATERIALS: Studs are available in Aluminum. For specific grade information and physical and chemical properties, and conforming standards, please see [General Material Specifications](#).

RECOMMENDED ACCESSORIES SPECIFICATION

Cap for N3A and N3P Pins

Caps are used in conjunction with Nelson N3A and N3P pins to secure many types of insulation to steel plate.

When ordering, specify: Type, Description, Material, Quantity

Example: N3A Insulation Cap Aluminum 10,000 pieces

Description	Part Number
Insulation Cap	101304002

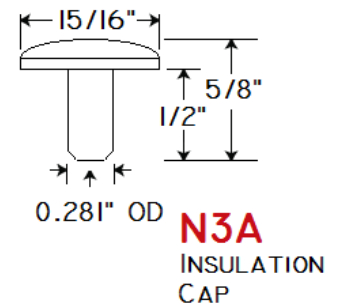

Materials: The Navy pin cap is supplied in Aluminum. For specific grade information and physical and chemical properties, and conforming standards, please see [General Material Specifications](#).

Studs

Cable Hangers for Stud Welding

NELSON STUD WELDING SPECIFICATION

CrimpLok™ Cable Hangers

Nelson marine hangers are generally used in the shipbuilding industry to support and retain electrical cables. They are mounted on CPL studs that have been welded to the ship's structure. The hangers have been vibration tested, and are United States Navy approved.

CrimpLok™ style hangers are crimped directly onto the cables to retain them, and are made from stainless steel or mild steel with an electrozinc or neoprene coating option.

Nelson's CrimpLok™ marine cable hangers combine the split-second fastening capabilities of stud welding with a proven method of cable attachment. The hanger has enough design flexibility to handle different diameters and quantities of cables, yet has very desirable mounting simplicity and speed.

The use of Nelson's studs and marine cable hangers allows painting and insulation to be installed prior to permanent cable installation, thus reducing time spent on overall component installation.

All studs cable hangers, seen above, are tapped 3/8"-16.

For similar function studs, see Nelson [Banding style cable hangers](#).

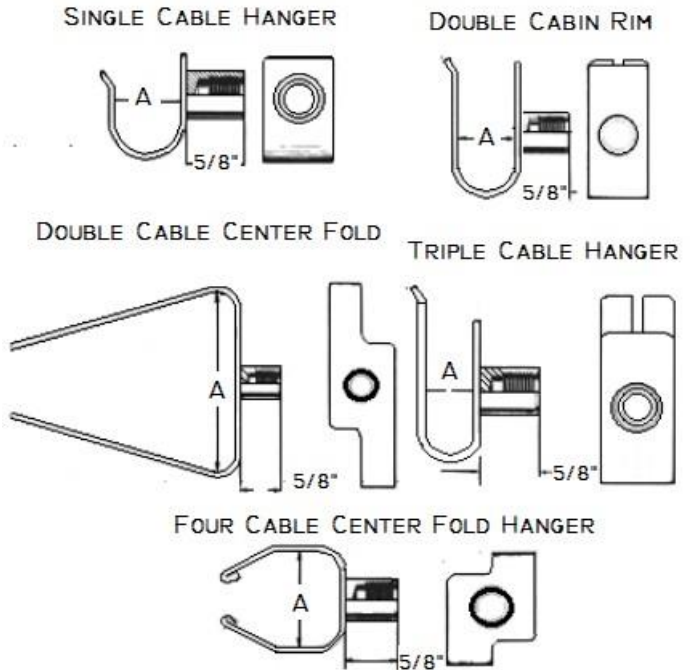

When ordering, specify: Type, Description, Material, Quantity, Part Number

Example: SL0103-TXL 0.531"; Mild Steel; 10,000 pieces; #101107126

Part Description	A	Cable Diameter	
		Minimum	Maximum
Single Cable Hanger			
SL0103-TXL	0.531	0.375	0.531
SL0105-TXL	0.680	0.531	0.680
SL0106-TXL	0.900	0.680	0.900
SL0107-TXL	1.224	0.900	1.224
SL0114-TXL	0.750	0.437	0.750
SL0131-TXL	0.358	0.305	0.371
Double Center Fold Hanger			
SL0109-TXL	0.531	0.375	0.531
SL0110-TXL	0.680	0.531	0.680
SL0111-TXL	0.900	0.680	0.900
SL0115-TXL	0.750	0.437	0.750
SL0117-TXL	1.000	0.750	1.000
SL0132-TXL	0.358	0.303	0.359

Part Description	A	Maximum Cable Diameter
Double Rim Fold Cable Hanger		
SL0104-TXL	3.000	0.500
SL0122-TXL	3.000	0.750
SL0123-TXL	2.000	1.000
SL0121-TXL	2.448	1.224
Triple Cable Hanger		
SL0104-TXL	0.531	0.531
Four Cable Center Fold Hanger		
SL0102-TXL	1.000	0.531

MATERIALS: Nelson cable hangers are available in Low Carbon Mild Steel and Stainless Steel. Options for electro-zinc plating and Neoprene coating are available. For specific grade information and physical and chemical properties, conforming standards, and information on stud plating, please see [General Material Specifications](#).

Studs

Cable Hangers for Stud Welding

NELSON STUD WELDING SPECIFICATION

Banding Style Cable Hangers

Nelson marine cable hangers are commonly used in the shipbuilding industry to support and retain electrical cables. They are mounted on CPL or CKL studs that have been welded to the ship's structure. These hangers have been shock and vibration tested, and approved by the United States Navy.

After the hangers are mounted on Nelson threaded studs 3/4" wide bands or hose clamps are installed to retain the cables. They can be supplied in stainless steel or mild steel with electro-zinc plating depending on the degree of corrosion protection required.

Nelson's banding style marine cable hangers combine the split-second fastening capabilities of stud welding with a tested and proven method of cable attachment. These hangers combine the design flexibility needed to handle different diameters and quantities of cables, with simplicity and speed.

The use of Nelson studs and marine cable hangers allows for painting and insulation to be installed prior to cable installation, thus reducing time spent on overall component installation.

For similar function studs, see Nelson [CrimpLok™ style cable hangers](#).

When ordering, specify: Type, Description, Material, Quantity, Part Number

Example: SL0130-2 3.000"; Mild Steel; 10,000 pieces; #101091019

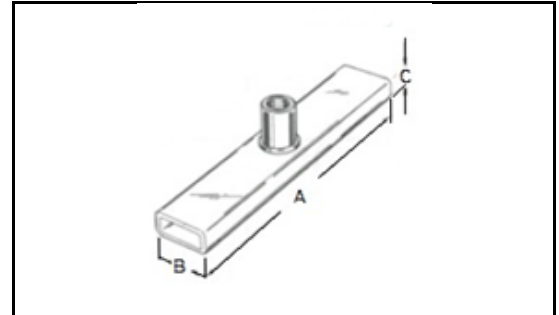

Banding Style Tubular Cable Hanger

Part Description	Length	Width B	Thick C
SL0249 TXL	1.500	0.875	0.375
SL0250 TXL	2.500	0.875	0.375
SL0251 TXL	3.500	0.875	0.375
SL0252 TXL	4.500	0.875	0.375
SL0253 TXL	5.500	0.875	0.375
SL0254 TXL	6.500	0.875	0.375
SL0255 TXL	7.500	0.875	0.375

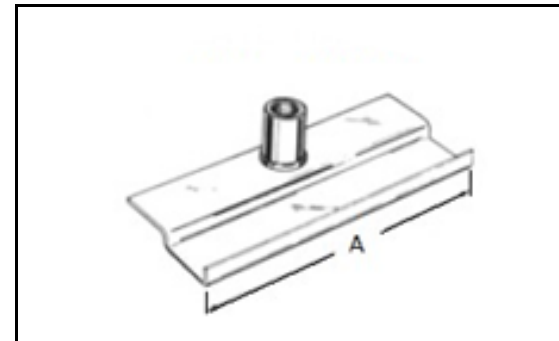

Banding Style Plate Cable Hangers for mounting on CPL studs

Part Description	Length A
SL0130-1	2.000
SL0130-2	3.000
SL0130-3	4.000
SL0129	6.000

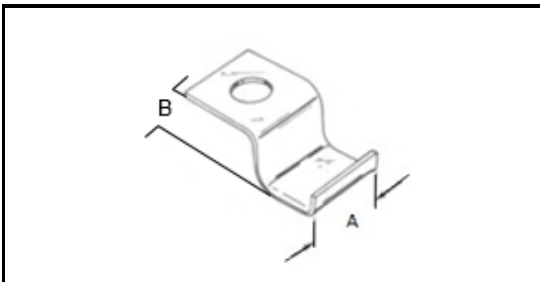

Thru Bolt Hangers for mounting on CKL studs

Part Description	Width A	B
Type I, #1161	0.750	0.500
Type II, #1162	1.000	0.500
Type II, #1162	1.500	0.500
Type II, #1162	2.000	0.500
Type III, #1163	2.500	0.500

MATERIALS: Nelson cable hangers are available in Low Carbon Mild Steel and Stainless Steel. Options for electrozinc plating and Neoprene coating are available. For specific grade information and physical and chemical properties, conforming standards, and information on stud plating, please see [General Material Specifications](#).

Studs

Refractory Anchors for Stud Welding

NELSON STUD WELDING SPECIFICATION

F3L Flanged Collar Studs

F3L studs are used as anchors to secure various refractory materials. Their most common use is for attachment of curved refractory blocks to steel skid tubes in steel mills. Wires are wrapped under the collars and around the blocks.

Cast, troweled, or gunned refractory is also applied over Nelson F3L studs. Various lengths of F3L studs are available, and are produced to accommodate different thickness of block or applied refractory.

For similar function studs, see Nelson [CKL Collar Studs](#).

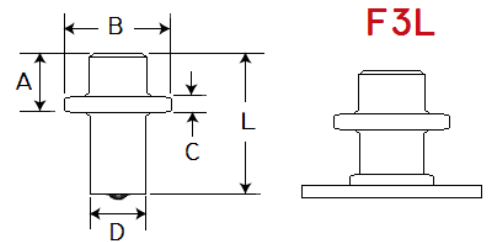

When ordering, specify: Type, Description, Material, Quantity, Part Number

Example: F3L 3/8 x 1-1/2"; Mild Steel; 10,000 pieces; #101041004

Stud Description	Stud Diameter D	A	B	C	Ferrule*	Required Standard Accessories		
						Grip	Chuck Assembly	Foot**
1/2 x L	0.500	0.500	0.875	0.125	100101119	501001012	500001014	502001138

* Ferrule used to weld 3" diameter pipe 100102026.

** 502001138 foot is used with standard duty guns. 502001002 foot is used with heavy duty guns.

MATERIALS: Studs are available in Low Carbon Mild Steel and 18-8 Stainless Steel. For specific grade information and physical and chemical properties, conforming standards, and information on stud plating and heat treating, please see [General Material Specifications](#).

FLUX: All Nelson F3L studs have a solid flux load.

Studs

Refractory Anchors for Stud Welding

NELSON STUD WELDING SPECIFICATION

L2L Lagging Studs with Hole

L2L studs are welded to hot work, such as furnaces, kilns, ducts, or tanks. They are intended for the attachment of insulation blankets using wires or “gull wing” wire skewers.

Nelson L2L studs are also welded around openings in plates for retention of cover plates with wedge pins inserted through the slots.

For similar function studs, see Nelson [R6P Rectangular Slotted studs](#), [E2L “Eyebolt” studs](#), and [R7P Rectangular Studs with Hole](#).

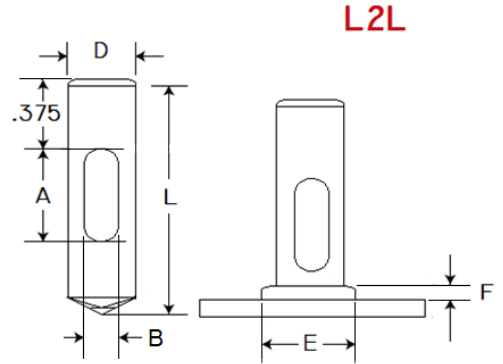

When ordering, specify: Type, Description, Material, Quantity, Part Number

Example: L2L 3/8 x 1-1/2”; Mild Steel; 10,000 pieces; #101060013

Stud Description	Stud Diameter D	A	B	Weld Flash		Required Standard Accessories			
				Diameter E	Height F	Ferrule	Chuck Assembly	Foot*	Grip
3/8 x L	0.375	0.500	0.156	0.500	0.125	10010109	500001011	50200113	501001009

* 502001137 foot is used with standard duty guns. 502001001 foot is used with heavy duty guns.

MATERIALS: Studs are available in Low Carbon Mild Steel and 18-8 Stainless Steel. For specific grade information and physical and chemical properties, conforming standards, and information on stud plating and heat treating, please see [General Material Specifications](#).

FLUX: All Nelson L2L studs have a solid flux load.

Studs

Refractory Anchors for Stud Welding

NELSON STUD WELDING SPECIFICATION

S4X "Y" Refractory Anchor Studs

Nelson S4X refractory studs are used to secure single component castable or gunite linings of medium to heavy density material (up to 170 lb. per cubic foot). S4X studs are used on the lining of petroleum and petrochemical towers, boilers, precipitators, heaters, stacks, and breechings, and in other situations where extreme temperature is not encountered. The use of S4X studs with one-shot linings is well established.

One leg of the S4X stud is shorter than the other to eliminate any shear plane failure tendencies common to higher density materials at elevated temperatures.

Nelson S4X studs are available in lengths up to 8" before weld length. After weld length is approximately 1/8" less than the before weld length.

For similar function Nelson studs, please see [R2P Rectangular Notched studs](#), [R6P Rectangular Slotted studs](#), [S7X "Steerhorn" Anchors](#), [RWP Wiggley Rectangular Two Tine studs](#), and [B4L Reinforcing Standoff Support studs](#).

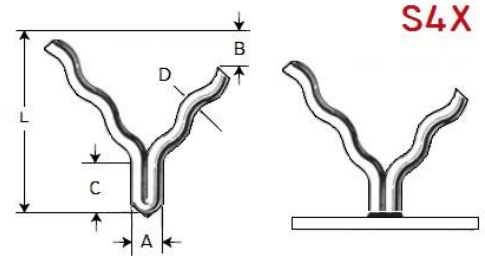

When ordering, specify: Type, Diameter, Length, Material, Quantity, Part Number

Example: S7X 3/16 x 1.625"; Mild Steel; 10,000 pieces; #101122003

D	Minimum L	A	B	C	Required Standard Accessories		
					Ferrule	Chuck	Grip/Foot
0.250	2.000	0.562	0.500	0.750	100101127	500015073	501006018

MATERIALS: Studs are available in Low Carbon Mild Steel and 18-8 Stainless Steel. Material selection is dependent on anticipated service temperature range. For specific grade information and physical and chemical properties, conforming standards, and information on stud plating and heat treating, please see [General Material Specifications](#).

FLUX: All Nelson S4X studs have a solid flux load.

Studs

Refractory Anchors for Stud Welding NELSON STUD WELDING SPECIFICATION S7X Steerhorn Refractory Anchor Studs

Nelson S7X refractory studs are used to secure castable or gunite linings of light to medium density material (up to 90 lb. per cubic foot). It is used on the lining of petroleum and petrochemical process industry furnaces, heaters, stacks, breechings, and in other situations where extreme temperature is not encountered. Its use with one-shot linings is well established.

The measurement from tine to tine across the top of the S7X stud is designed to be approximately twice the overall height of the anchor. The after weld length of S7X studs will be approximately 1/8" less than the before weld length.

For similar function Nelson studs, please see [R2P Rectangular Notched studs](#), [R6P Rectangular Slotted studs](#), [S4X "Y" Anchors](#), [RWP Wiggley Rectangular Two Tine studs](#), and [B4L Reinforcing Standoff Support studs](#).

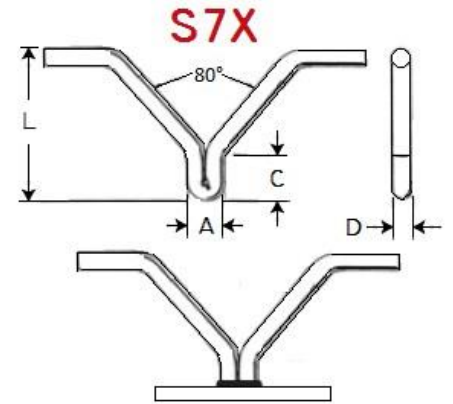

When ordering, specify: Type, Description, Material, Quantity, Part Number
Example: S7X 3/16 x 1.625"; Mild Steel; 10,000 pieces; #101122003

D	Minimum L	A	C	Required Standard Accessories		
				Ferrule	Chuck	Grip/Foot
3/16	1.125	0.515	0.625	100101170	500015073	501006018

MATERIALS: Studs are available in Low Carbon Mild Steel and 18-8 Stainless Steel. Material selection is dependent on anticipated service temperature range. For specific grade information and physical and chemical properties, conforming standards, and information on stud plating and heat treating, please see [General Material Specifications](#).

Studs

Rectangular Studs

NELSON STUD WELDING SPECIFICATION

R1P and R1L Rectangular Stud without Hole

Nelson R1P and R1L studs are used for a variety of purposes. Frequently, they are used as stops, standoffs, or tabs for locating or positioning parts in assemblies. They are also used as refractory anchors to increase the surface area of furnaces or molds, where they act as cooling fins.

The smaller, 1/8 x 1/4", 1/8 x 3/8", and 1/8 x 5/8" weld base rectangular studs have a sufficiently small weld base so as to not require a flux load in the weld end of the stud. For this reason, these are called R1P studs.

The 3/16" and thicker rectangular weld base studs are flux loaded due to the increased volume of steel melted during the weld process. These studs are called R1L studs.

Rectangular studs capable of performing similar duties include [R2P Rectangular Notched studs](#), [R5P Strand Support studs](#), [R6P Rectangular Slotted studs](#), [R7P rectangular Stud with Hole](#), and [RWP Wiggley Two Tine Refractory Anchors](#).

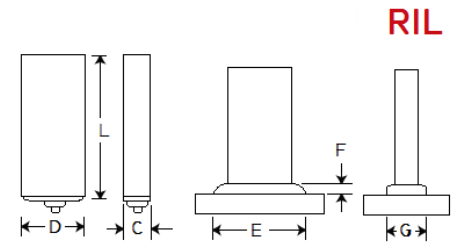

When ordering, specify: Type, Description, Material, Quantity, Part Number
Example #1: R1P 1/8 x 5/8 x 1"; Stainless Steel; 5,000 pieces; # 101085137
Example #2: R1L 3/8 x 1 x 3"; Mild Steel; 5,000 pieces; #101085111

Stud Description	Minimum Length	Stud Dimensions		Weld Flash Dimensions			Required Standard Accessories			
		C	D	E	F	G	Ferrule	Chuck	Grip	Foot
1/8 x 1/4	1.000	0.125	0.250	0.312	0.093	.0218	100301014	500005118	501001006	502001137
1/8 x 3/8	1.000	0.125	0.375	0.437	0.093	.0218	100301002	500005003	501001007	502001137
1/8 x 5/8	1.000	0.125	0.375	0.687	0.093	0.218	100301003	500005014	501001012	502001138
3/16 x 5/8	1.000	0.187	0.625	0.750	0.125	0.312	100301007	*	N/A ¹	503003000
3/16 x 3/4	1.000	0.187	0.750	0.875	0.125	0.312	100301006	500005007	501001012	502001138
1/4 x 1	1.000	0.250	1.000	1.125	0.187	0.406	100301010	500005012	501001015	502001003
1/4 x 1-1/4	1.250	0.250	1.250	1.468	0.187	0.468	100301012	500005019	N/A ¹	503001000
3/8 x 1"	1.000	0.375	1.000	1.156	0.218	0.515	101301023	500005101	N/A ¹	503022000

* No chuck is shown for 3/16 x 5/8 rectangular studs due to the fact that the 3/16 x 5/8" ferrule and weld base is used on studs that have a wider upper section. Chucks are available for 3/16 x 3/4, 7/8, 1, or even 1-1/2" wide studs. The upper portion of the stud determines the chuck that is needed to hold the studs during the stud welding process.

¹ The foot assembly functions as the ferrule grip. No grip is needed.

MATERIALS: R1P and R1L studs are available in Low Carbon Mild Steel and 18-8 Stainless Steel. Other materials are available by special order. For specific grade information and physical and chemical properties, conforming standards, and information on stud plating and heat treating, please see [General Material Specifications](#).

Studs

Rectangular Studs

NELSON STUD WELDING SPECIFICATION

R2P Rectangular Notched Stud

Nelson R2P studs are used in a variety of ways to secure one and two component refractory linings. The refractory may be low density blanket or block, or medium to high density cast, gunned, or troweled insulation.

When used with a single component cast, gunned, or troweled lining, the R2P is welded, the tines spread, and the refractory placed.

With two component linings, the R2P is welded, the back-up layer placed, the tines bent, and the working lining placed over the bent tines. We suggest that the tines be spread to a maximum central angle of 70°. Spreading the tines may be easily done with a piece of small diameter pipe or a set of pliers.

The Nelson R2P is also used to secure block insulation alone. In this case, the stud is welded in place, the insulation impaled over the stud, and the tines bent flush with the insulation. The 1/8 x 3/8 R2P is most frequently used for this service, with the length chosen so that the tines protrude at least 1-1/2" beyond the impaled insulation before bending.

For similar function studs, see Nelson [CKL Collar studs](#), [R5P Strand Support studs](#), [R6P Rectangular Slotted studs](#), [R7P Rectangular Stud with Hole](#), [RWP Wiggley Two Tine studs](#), [RXX Fiberlok studs](#), [S4X "Y" Anchors](#), and [S7X Steerhorn Anchors](#).

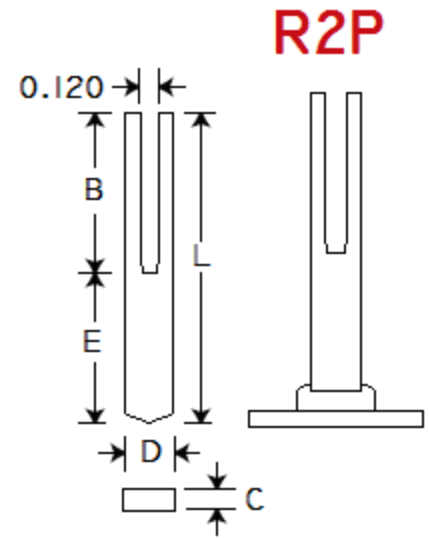

When ordering, specify: Type, Description, Material, Quantity, Part Number
 Example: R2P 1/8 x 3/8 x 1-1/2"; Mild Steel; 10,000 pieces; #101086113

Stud Description	Thickness C	Stud Dimensions					Required Standard Accessories			
		Width D	B	E	Minimum Length	Maximum Length	Ferrule	Chuck	Grip	Foot
1/8 x 3/8	0.125	0.375	1.250	0.250	1.500	6.125	100301002	500005003	501001007	502001137
1/8 x 5/8	0.125	0.625	2.000	0.312	2.312	6.125	100301003	500005014	501001012	502001138
1/8 x 5/8	0.125	0.625	0.75 to 4.000	0.312	1.625	4.875	100301003	500005014	501001012	502001138
1/8 x 5/8	0.125	0.625	0.75 to 4.000	0.625	1.625	4.875	100301003	500005014	501001012	502001138
1/8 x 5/8	0.125	0.625	0.75 to 4.000	0.875	1.625	4.875	100301003	500005014	501001012	502001138

MATERIALS: Studs are available in Low Carbon Mild Steel and 18-8 Stainless Steel. Other materials are available by special order. For specific grade information and physical and chemical properties, conforming standards, and information on stud plating and heat treating, please see [General Material Specifications](#).

Studs

Rectangular Studs

NELSON STUD WELDING SPECIFICATION

R5P Strand Support Stud

Nelson R5P studs are welded to plates that are cast into pre-stressed concrete beams and structural members for building construction. The studs are positioned so that a pre-stressed cable strand bears on the notch in the end of the stud. The strand pressure applied to the stud and plate assembly keeps the plate securely in place against the form while the concrete is poured and has cured.

The bottom of the notch, which determines the height of the strand, can be calculated by subtracting the 3/4" notch depth and the 1/8" weld burn-off, from the overall length of the R5P stud.

Older R8P style strand supports had only a shallow "V" notch in the top of the stud. The notch was not reliable for keeping the cable strand in place. The R5P studs have a crimpable deep notch with ears that can be crimped over the cables. D2L and H4L studs are often welded to the same plates as the R5P studs.

Rectangular studs capable of performing similar duties include R2P Rectangular Notched studs, R6P Rectangular Slotted studs, R7P Rectangular Stud with Hole, and RWP Wiggley Two Tine Refractory Anchors.

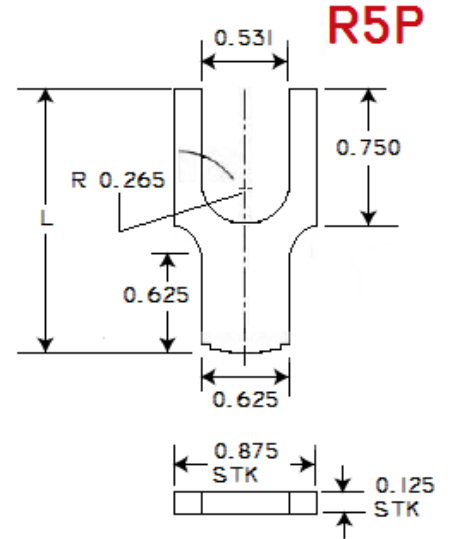

When ordering, specify: Thickness, Width, Length, Material, Quantity, Part Number

Example: R5P 1/8 x 7/8 x 2"; Mild Steel; 5,000 pieces; # 101084226

Thickness	Width	Minimum Length	Required Standard Accessories		
			Ferrule	Chuck	Ferrule Foot Plate
1/8	0.875	1.500	100301003	500005005	501006011

MATERIALS: Studs are available in Low Carbon Mild Steel and 18-8 Stainless Steel. Other materials are available by special order. For specific grade information and physical and chemical properties, conforming standards, and information on stud plating and heat treating, please see [General Material Specifications](#).

Studs

Rectangular Studs

NELSON STUD WELDING SPECIFICATION

R6P Rectangular Slotted Stud

R6P rectangular notched studs are used to attach wire reinforcing mesh to steel furnace and chimney liners. The mesh is used to anchor sprayed, gunned, or troweled refractory. R6P studs are also used to position wire mesh in poured concrete assemblies, such as enforcing lined concrete piping. The stud length to the notch determines the height of the reinforcing wire.

Additional security and stability may be gained by bending over the top portion of the stud to lock the wire in place and prevent slippage

For similar function studs, see Nelson [R2P Rectangular Notched studs](#), [R7P Rectangular Studs with Hole](#), [RWP Wiggley Rectangular Two Tine studs](#), and [B4L Reinforcing Standoff Support studs](#).

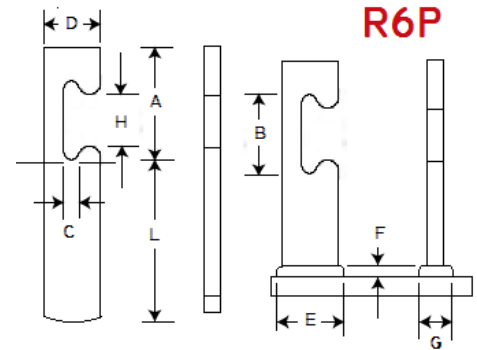

When ordering, specify: Type, Description, Material, Quantity, Part number
 Example: R6P 1/8 x 3/8 x 1-1/2"; Mild Steel; 10,000 pieces; #101090011

Stud Description	Minimum Length*	Stud Dimensions					Weld Flash			Required Standard Accessories			
		D	A	B	C	H	E	F	G	Ferrule	Chuck	Grip	Foot
1/8 x 3/8	1/2	0.375	0.749	0.531	0.130	0.343	0.437	0.093	0.218	100301002	500005003	501001007	502001137
1/8 x 5/8	7/8	0.625	1.250	1.000	0.255	0.562	0.687	0.093	0.218	100301003	500005014	501001012	502001138

*Length does not include the A dimension which is bent over the wire mesh.

MATERIALS: Studs are available in Low Carbon Mild Steel and Stainless Steel. Other materials are available by special order. For specific grade information and physical and chemical properties, conforming standards, and information on stud plating and heat treating, please see [General Material Specifications](#).

Studs

Rectangular Studs

NELSON STUD WELDING SPECIFICATION

R7P Rectangular Slotted Stud

R7P rectangular studs with holes are used for a variety of fastening purposes. Wires or bolts may pass through the holes for suspending ceilings. Nelson studs can also be used to suspend assemblies on conveyor lines during painting and baking operations.

For similar function studs, see Nelson [R2P Notched Rectangular stud](#), [R5P Strand Support stud](#), [R6P Slotted Rectangular stud](#), [R9L Rope Hook studs](#), [E2L "Eyebolt" studs](#), [J2L "J" Bolt studs](#), and [L2L Lagged stud with Hole](#).

R7P

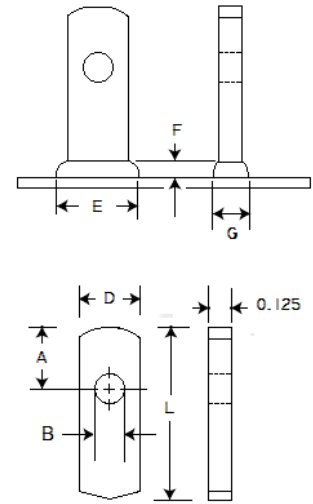

When ordering, specify: Type, Description, Material, Quantity, Part no
Example: R7P 1/8 x 3/8 x 1"; Mild Steel; 10,000 pieces; #101091008

Stud Description	Minimum Length L	Stud Dimensions				Weld Flash Dimensions		Required Standard Accessories			
		D	A	B	E	F	G	Ferrule	Chuck	Grip	Foot
1/8 x 3/8	1.000	0.375	0.312	0.203	0.437	0.093	0.218	100301002	500005003	501001007	502001137
1/8 x 5/8	1.500	0.625	0.312	0.312	0.687	0.093	0.218	100301003	500005014	501001012	502001138

MATERIALS: Studs are available in Low Carbon Mild Steel and Stainless Steel. Other materials are available by special order. For specific grade information and physical and chemical properties, conforming standards, and information on stud plating and heat treating, please see [General Material Specifications](#).

Studs

Rectangular Studs

NELSON STUD WELDING SPECIFICATION

RWP Wiggley Strand Support Stud

Nelson RWP rectangular two tine studs are designed for securing both one and two component medium and high density refractory linings. The deformed tines prevent the anchor from “backingout” of the lining while in service.

RWP studs are supplied with tines parallel to each other. The studs are welded in this configuration, and in this position blanket insulation may be impaled. The tines may then be spread, and cast or gunned insulation may be further applied to the wiggled “Y” anchor that protrudes.

Nelson RWP studs are available in lengths up to 13”. The studs up to 2-1/8” to 3” long have a 1-1/2” tine length and a single deformation. Studs 3-1/8” to 4” long have tine lengths of 2-1/2” with two deformations. Studs over 4-1/8” in length have 3-1/2” tine lengths with three deformations.

For similar function studs, see Nelson [R2P Rectangular Notched studs](#), [R6P Rectangular Slotted studs](#), [S4X “Y” Anchor studs](#), [S7X Steerhorn Anchors](#), and [B4L Reinforcing Standoff Support studs](#).

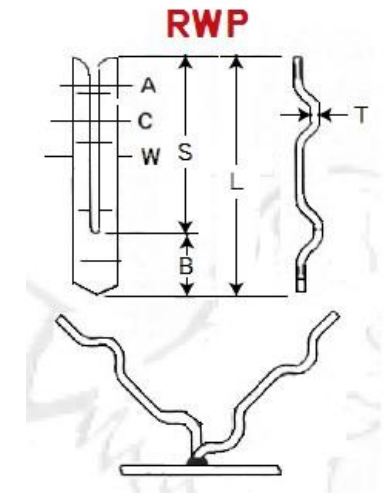

When ordering, specify: Type, Thickness, Width, Length, Material, Quantity, Part Number

Example: RWP 1/8 x 5/8 x 4”; Mild Steel; 5,000 pieces; #101119041

Standard Tine Length S	Minimum Base Length B	Minimum Length L	T	W	A	C	Required Standard Accessories			
							Ferrule	Chuck	Foot	Grip
1.500	0.500	2.125	0.125	0.625	0.250	0.125	100301003	500005014	502001002	501001012
2.500	0.500	3.125	0.125	0.625	0.250	0.125	100301003	500005014	502001002	501001012
3.500	0.500	4.125	0.125	0.625	0.250	0.125	100301003	500005014	502001002	501001012

MATERIALS: Studs are available in Low Carbon Mild Steel and Stainless Steel. Other materials are available by special order. For specific grade information and physical and chemical properties, conforming standards, and information on stud plating and heat treating, please see [General Material Specifications](#).

Studs

Rectangular Studs

NELSON STUD WELDING SPECIFICATION

RXX FiberLok™ Stud

Nelson RXX Fiberlok™ studs and washers are a designed system to retain high temperature ceramic fiber blanket insulation to furnaces.

Installation of the retaining clips or washers is accomplished by compressing the blanket and turning the clip 90° at the bottom of a tapered notch. The resilience of the blanket pushes the clip up to the wider top portion of the notch, locking it in place.

Because of the high temperature requirements of this application, these studs and clips are not available in mild steel. The standard studs have five notches, each of which has a pitch of 1/2" (two notches per inch). Studs smaller than 3-1/2" feature only two notches. Studs can be supplied in lengths over 12" if needed.

With longer RXX studs, split foot #502002045 and split grip #501003006 may be used in place of the closed grip and foot, shown below, for faster stud loading.

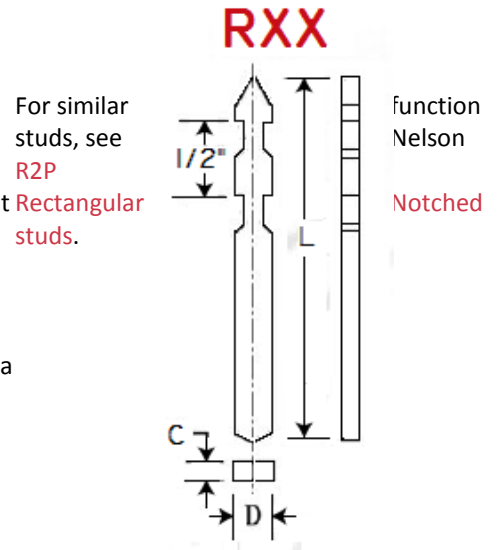

When ordering, specify: Type, Description, Material, Quantity, Part Number
 Example: RXX 1/8 x 1/4 x 4-1/2"; Inconel 601; 10,000 pieces; #101084107

Stud Description	Minimum Length	Stud Dimensions		Required Standard Accessories			
		D	C	Ferrule	Chuck	Grip	Foot
1/8 x 1/4	3.500	0.250	0.125	100301014	500005118	501001006	502001137

MATERIALS: Studs are available in Inconel 601 and 18-8 Stainless Steel. For specific grade information and physical and chemical properties, conforming standards, and information on stud plating and heat treating, please see [General Material Specifications](#).

RECOMMENDED ACCESSORIES SPECIFICATION

Fiberlok™ Washer

Fiberlok™ washers are available in high temperature alloys, and are engineered for use with RXX Fiberlok™ studs.

When ordering, specify: Type, Description, Material, Quantity, Part Number

Example: Fiberlok™ washer; 304 Stainless Steel; 10,000 pieces; #101300144

MATERIALS: The Fiberlok™ washer is available in the aforementioned materials. For specific grade information and physical and chemical properties, conforming standards, and information on washer plating and heat treating, please see [General Material Specifications](#).

Alloy	Part Number	Max Temperature
304 Stainless	101300144	1500 °F
310 Stainless	101300145	2050 °F
Inconel 601	101300143	2300 °F
330 Stainless	101300148	2200 °F

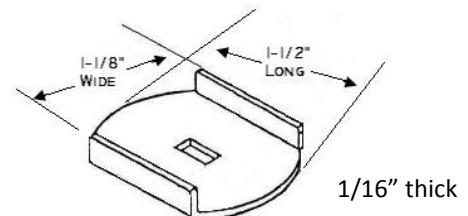

Studs

Insulation Pins

NELSON STUD WELDING SPECIFICATION

CHP Cupped Head Insulation Pins

CHP studs are designed to weld through and secure blanket insulation to metal heating and air-conditioning ducts, ovens, tanks, boilers, and other hot or cold equipment. The studs are welded through the insulation for a one-step attachment. The insulation blanket may be fiberglass, rock wool, or other low-density insulation.

Cupped Head Pins may also be used to anchor sprayed or gunned-on fireproofing to structural steel members in buildings to protect them from heat in the event of a fire. This protection slows the loss of structural strength to increase the time available for evacuation, and reduces the likelihood that beams will buckle or collapse.

The pins may also be welded to cellular sheet metal deck to guarantee permanent anchorage of the sprayed fireproofing which protects electrical wires running through the cells, and provides added fire resistance per UL 263 and ASTM E119 standards, Fire Tests of Building Construction and Materials. In addition to securing the fireproofing, the pins also act as a reference gauge for the thickness of fireproofing to be applied.

For similar function studs, see Nelson [TPC Single Pointed Insulation Pins](#), [P2P Double Pointed Insulation Pins](#), and [N3P Navy Type Annular Ring studs](#).

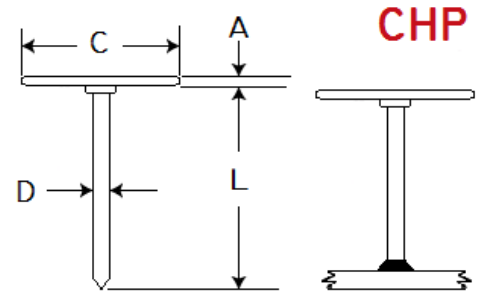

When ordering, specify: Type, Description, Material, Quantity, Part Number

Example: CHP 12 ga. x 1"; Mild Steel; 10,000 pieces; #101124100

Stud Description	Pin Diameter D	Minimum Length L	Head Diameter C	A	Required Standard Accessories	
					Chuck Assembly*	Foot Assembly
12 ga.	0.105	0.500	1.187	0.021	500015094	503011050
10 ga.	0.134	1.375	1.500	0.021	500015095	503011050

* The above chucks have a 3/8" diameter shank and need to be used with chuck adapter #3521001023 to mount them on stud welding guns with female #2 Morse taper chuck adapters.

MATERIALS: CHP studs are available with Low Carbon Mild Steel shanks and galvanized sheet metal heads. For specific grade information and physical and chemical properties, please see [General Material Specifications](#).

Studs

Insulation Pins

NELSON STUD WELDING SPECIFICATION

N3P Navy Type Annular Ring Studs

N3P Navy pins are welded to steel for attachment of insulation. The insulation is impaled over the welded studs and retained with caps that are driven onto the studs, and lock onto the annular rings.

The flat top caps for use with N3P pins are usually supplied in aluminum. Caps can be supplied in plated mild steel or stainless steel, if needed.

The standard N3P cap is shown.

For similar function studs, see Nelson [P2P Double pointed Insulation Pins](#), [TPC Single Pointed Insulation Pins](#), and [CHP Cupped Head Insulation Pins](#).

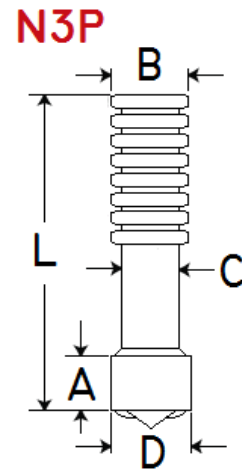

When ordering, specify: Type, Description, Material, Quantity, Part Number

Example: N3P 3/16 x 1"; Mild Steel; 10,000 pieces; #101074014

Stud Description	Minimum Length L	D	A	B	C	Required Standard Accessories			
						Ferrule	Chuck	Grip	Foot
3/16 x L	1.000	0.188	0.250	0.176	0.172	100101003	500001005	501001004	502001137*

*502001137 feet used with standard duty guns. 502001001 feet used with heavy duty guns.

MATERIALS: Studs are available in Low Carbon Mild Steel and 18-8 Stainless Steel. Other materials are available by special order. For specific grade information and physical and chemical properties, conforming standards, and information on stud plating and heat treating, please see [General Material Specifications](#).

RECOMMENDED ACCESSORIES SPECIFICATION

Cap for N3A and N3P Pins

Caps are used in conjunction with Nelson N3A and N3P pins to secure many types of insulation to steel plate.

When ordering, specify: Type, Description, Material, Quantity

Example: N3P Insulation Cap; Aluminum; 10,000 pieces

Description	Part Number
Insulation Cap	101304021

Materials: The Navy pin cap is supplied in Aluminum. For specific grade information and physical and chemical properties, and conforming standards, please see [General Material Specifications](#).

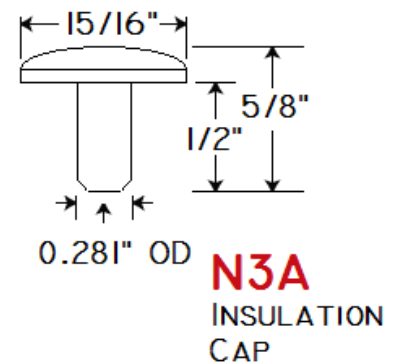

Studs

Insulation Pins

NELSON STUD WELDING SPECIFICATION

P2P Double Pointed Insulation Pin

P2P studs are stud welded to structural steel to secure blanket and board insulation to ovens, tanks, boilers, and other hot or cold equipment. The insulation may be fiberglass, rock wool, or other insulation.

When used in combination with Speed Clips, the resultant system is a simple, inexpensive, and efficient method of securing insulation to metal backings. Stud length should be longer than the insulation thickness to aid in securing Speed Clips.

For similar function studs, see Nelson [TPC Single Pointed Insulation Pins](#), [N3P navy Type Annular Ring studs](#), and [CHP Cupped Head Insulation pins](#).

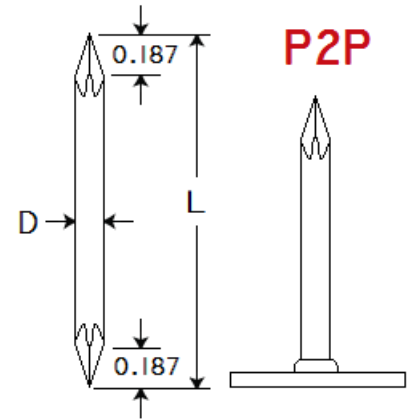

When ordering, specify: Type, Description, Material, Quantity, Part Number
 Example: P2P 10 ga. x 1-1/2"; Mild Steel; 10,000 pieces; #101126150

Stud Description	Pin Diameter D	Minimum Length L	Required Standard Accessories			
			Ferrule	Grip	Chuck	Foot*
10 ga.	0.134	1.000	100101002	501001003	500001002	502001137

MATERIALS: Studs are available in Low Carbon Mild Steel and 18-8 Stainless Steel. Other materials are available by special order. For specific grade information and physical and chemical properties, conforming standards, and information on stud plating and heat treating, please see [General Material Specifications](#).

RECOMMENDED ACCESSORIES SPECIFICATION

Speed Clips

Speed clips, when used in combination with P2P studs, secure all types of material that can be readily impaled: fiberglass, foam, felts, and corks, as well as refractory linings and light-density insulation board.

When ordering, specify: Type, Description, Material, Quantity

Example: Speed Clip 10 ga. x 1-1/2" Round; Stainless Steel; 10,000 pieces; #101301084

Clip Description	Pin Size C	Clip Diameter D	Clip Thickness
Round	10ga.	1-1/2	0.021
Round	10ga.	2	0.021
Square	10ga.	1-1/2	0.021
Square	10ga.	2-1/2	0.021
Rectangular	10ga.	1 x 1-1/4	0.021

RECTANGULAR SQUARE IMPRESSION CLIP

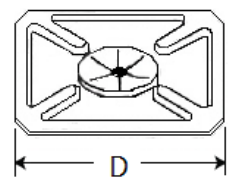

ROUND IMPRESSION CLIP

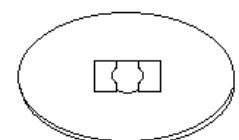

MATERIALS: Speed Clips are available in zinc plated Low Carbon Mild Steel and 18-8 Stainless Steel. Other materials are available by special order. For specific grade information and physical and chemical properties, conforming standards, and information on stud plating and heat treating, please see [General Material Specifications](#).

Studs

Insulation Pins

NELSON STUD WELDING SPECIFICATION

TPC Single Pointed Insulation Pin

These studs are primarily designed as welded fasteners to secure blanket and board insulation to metal heating and air-conditioning duct, ovens, tanks, boilers, and other hot or cold equipment. The insulation may be fiberglass, rock wool, or other insulation

When used in combination with the Speed Clips, shown below, the resultant system is a simple, inexpensive, and efficient method of securing insulation to a metal backing.

The "TP" series of insulation pins have a weld tip designed for the Capacitor Discharge welding process, but they may also be welded with the Short Cycle Drawn Arc weld process.

For similar function studs, see Nelson [P2P Double Pointed Insulation Pins](#), [N3P Navy Type Annular Ring studs](#), and [CHP Cupped Head Insulation pins](#).

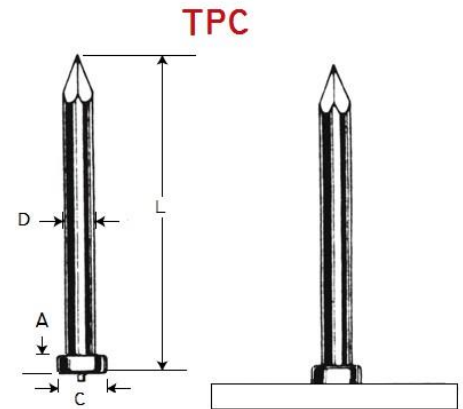

When ordering, specify: Type, Description, Material, Quantity, Part Number

Example: TPC 10 ga. x 6"; Mild Steel; 10,000 pieces; #101262061

Stud Description	Pin Diameter D	Minimum Length L	C	A	Required Standard Accessories		
					Spark Shield	Chuck	Foot
12 ga.	0.105	0.750	0.175	0.035	511001002	500001169	502001138
10 ga.	0.134	0.750	0.215	0.050	511001002	500001002	502001138

MATERIALS: Studs are available in Low Carbon Mild Steel (TPC), 18-8 Stainless Steel (TPS), and 1100 Aluminum (TPA). Other materials are available by special order. For specific grade information and physical and chemical properties, conforming standards, and information on stud plating and heat treating, please see [General Material Specifications](#).

RECOMMENDED ACCESSORIES SPECIFICATION

Speed Clips

Speed clips, when used in combination with TPC studs, secure all types of material that can be readily impaled: fiberglass, foam, felts, and corks, as well as refractory linings and light-density insulation board.

When ordering, specify: Type, Description, Material, Quantity

Example: Speed Clip 10 ga. x 1-1/2" Round; Stainless Steel; 10,000 pieces; #101301084

Clip Description	Pin Size C	Clip Diameter D	Clip Thickness
Round	10ga.	1-1/2	0.021
Round	10ga.	2	0.021
Square	10ga.	1-1/2	0.021
Square	10ga.	2-1/2	0.021
Rectangular	10ga.	1 x 1-1/4	0.021

RECTANGULAR SQUARE IMPRESSION CLIP

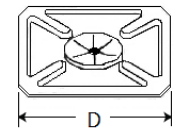

ROUND IMPRESSION CLIP

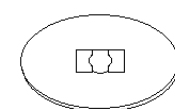

MATERIALS: Speed Clips are available in zinc plated Low Carbon Mild Steel and 18-8 Stainless Steel. Other materials are available by special order. For specific grade information and physical and chemical properties, conforming standards, and information on stud plating and heat treating, please see [General Material Specifications](#).

Ferrules

NELSON STUD WELDING SPECIFICATION

Ceramic ferrules are an essential part of the standard drawn arc stud welding process. They are designed to encircle the weld stud to protect the weld arc and limit it to a specific area of the base material. They also contain the molten weld metal and act as a mold to give a uniform shape to this metal, also called the weld flash. The term, weld flash, is used to distinguish the weld metal at the base of a stud from the weld by other arc welding processes, which is called weld fillet.

Standard Ferrules

These ferrules are intended for welding round studs perpendicular to flat surfaces.

Full Base

These ferrules are standard ferrules supplied with the full weld base **NBL, TBL, H4L, S3L, and D2L** studs.

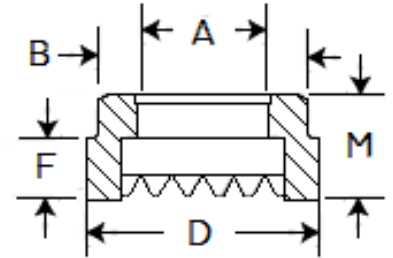

Nominal Stud Size	Inside Diameter A	Neck Diameter B	Major Diameter D	Height to Neck F	Height Overall M	Ferrule Part Number
#6	0.138	0.281	0.375	0.234	0.390	100101001
#8	0.164	0.291	0.375	0.234	0.390	100101002
#10	0.187	0.305	0.390	0.234	0.390	100101003
1/4	0.250	0.505	0.640	0.286	0.437	100101067
5/16	0.312	0.445	0.578	0.234	0.390	100101007
3/8	0.375	0.650	0.795	0.228	0.390	100101099
7/16	0.437	0.585	0.703	0.234	0.422	100101009
1/2	0.500	0.785	0.875	0.228	0.390	100101114
9/16	0.562	0.785	1.030	0.328	0.515	100101011
5/8	0.625	1.030	1.150	0.339	0.526	100101187
3/4	0.750	1.030	1.215	0.469	0.656	100101152
13/16	0.813	1.210	1.735	0.260	0.464	100101178
7/8	0.875	1.210	1.413	0.545	0.732	100101140
1	1.000	1.406	1.610	0.633	0.820	100101045
1-1/8	1.125	1.541	1.765	0.503	0.815	100101143
1-1/4	1.250	2.015	2.015	1.030	1.030	100101146

Full Base – Thin Wall

These special order ferrules are available for full base studs to accommodate special situations or fixturing.

Nominal Stud Size	Inside Diameter A	Neck Diameter B	Major Diameter D	Height to Neck F	Height Overall M	Ferrule Part Number
1/4	0.250	0.380	0.455	0.265	0.390	100101006
3/8	0.375	0.505	0.640	0.234	0.390	100101008
1/2	0.500	0.650	0.795	0.250	0.438	100101010
5/8	0.625	0.785	1.030	0.328	0.515	100101012

To determine the ferrule grips, ferrule holders, or ferrule tubes that can be used with specific ferrule types, look at the neck diameter (inside diameter) of the ferrule, then look in the accessories catalog for ferrule grips, holders, or tubes to match that inside diameter.

Ferrules

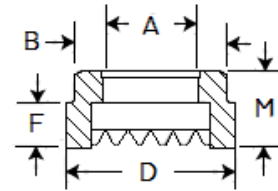

Full Base – Low Profile, F-139

These ferrules are available for short studs

Nominal Stud Size	Inside Diameter A	Neck Diameter B	Major Diameter D	Height to Neck F	Height Overall M	Ferrule Part Number	Minimum Stud Length
#10	0.187	0.305	0.390	0.125	0.250	100101063	0.625
1/4	0.250	0.370	0.455	0.125	0.250	100101077	0.640
5/16	0.312	0.505	0.596	0.125	0.250	100101030	0.640
3/8	0.375	0.585	0.675	0.125	0.250	100101031	0.687
3/8	0.375	0.785	0.875	0.160	0.281	100101101	0.718
7/16	0.437	0.650	0.740	0.125	0.281	100101032	0.687
1/2	0.500	0.785	0.875	0.174	0.281	100101115	0.750
1/2	0.500	0.921	1.030	0.125	0.312	100101119	0.718
1/2	0.500	1.030	1.187	0.125	0.281	100101122	0.718
5/8	0.625	0.921	1.030	0.187	0.375	100101126	0.813
3/4	0.750	1.210	1.413	0.203	0.390	100101133	0.875

Threaded Pitch Diameter, F-239

These ferrules are used with CPL type studs

Nominal Stud Size	Inside Diameter A	Neck Diameter B	Major Diameter D	Height to Neck F	Height Overall M	Ferrule Part Number
1/4-20	0.215	0.380	0.455	0.125	0.250	100101034
5/16-18	0.275	0.445	0.535	0.125	0.250	100101035
3/8-16	0.330	0.505	0.595	0.139	0.264	100101036
7/16-14	0.388	0.585	0.675	0.173	0.329	100101037
1/2-13	0.448	0.650	0.740	0.206	0.362	100101038
5/8-11	0.562	0.785	0.905	0.277	0.433	100101039
3/4-10	0.680	1.030	1.150	0.339	0.526	100101040
7/8-9	0.797	1.210	1.330	0.406	0.593	100101041
1-8	0.915	1.406	1.526	1.474	0.661	100101042

Full Threaded, F-107

These ferrules are used with CFL studs. For short studs, see low profile options in CFL catalog sheet.

Nominal Stud Size	Inside Diameter A	Neck Diameter B	Major Diameter D	Height to Neck F	Height Overall M	Ferrule Part Number
5/16-18	0.312	0.445	0.578	0.281	0.437	100101024
3/8-16	0.375	0.505	0.640	0.281	0.437	100101025
7/16-14	0.437	0.585	0.703	0.281	0.469	100101026
1/2-13	0.500	0.650	0.795	0.281	0.469	100101027
5/8-11	0.625	0.785	1.030	0.390	0.579	100101028
3/4-10	0.750	1.030	1.180	0.390	0.595	100101029

To determine the ferrule grips, ferrule holders, or ferrule tubes that can be used with specific ferrule types, look at the neck diameter (inside diameter) of the ferrule, then look in the accessories catalog for ferrule grips, holders, or tubes to match that inside diameter.

Ferrules

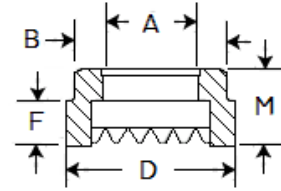

Collar Studs, F-172

These ferrules are used with **CKL** type studs

Nominal Stud Size	Inside Diameter A	Neck Diameter B	Major Diameter D	Height to Neck F	Height Overall M	Ferrule Part Number
#10-24, 32	0.187	0.650	0.740	0.090	0.195	100101060
1/4-20	0.215	0.785	0.875	0.095	0.235	100101066
5/16-18	0.275	0.785	0.875	0.095	0.235	100101073
3/8-16	0.330	0.785	0.875	0.095	0.250	100101083
1/2-13	0.448	0.921	1.030	0.125	0.250	100101118

Reduced Base, F-106

These ferrules are used with **CJL** and **NJL** type studs

Nominal Stud Size	Inside Diameter A	Neck Diameter B	Major Diameter D	Height to Neck F	Height Overall M	Ferrule Part Number
#10	0.187	0.305	0.305	0.234	0.390	100101015
1/4	0.250	0.380	0.455	0.175	0.390	100101016
5/16	0.312	0.445	0.578	0.281	0.437	100101017
3/8	0.375	0.505	0.640	0.281	0.437	100101018
1/2	0.500	0.650	0.795	0.327	0.515	100101020
5/8	0.625	0.785	1.030	0.391	0.579	100101021
3/4	0.750	0.921	1.100	0.391	0.595	100101022

Aluminum Ferrules

These aluminum ferrules are intended for welding round studs perpendicular to flat surfaces

Aluminum Studs, F-250

These ferrules are used with **HBA**, **CKA**, **TBA**, and **NBA** type studs

Nominal Stud Size	Inside Diameter A	Neck Diameter B	Major Diameter D	Height Overall M	Ferrule Part Number
3/16	0.187	0.750	0.750	0.250	100101046
1/4	0.250	0.750	0.750	0.250	100101047
5/16	0.312	0.750	0.750	0.250	100101048
3/8	0.375	1.000	1.000	0.385	100101049
7/16	0.437	1.000	1.000	0.385	100101050
1/2	0.500	1.000	1.000	0.385	100101051

NOTE: As there is no F dimension within the chart, disregard it within the drawing.

Ferrules

Special Ferrules

Internal Use Only

These ferrules are intended for welding round studs to flat surfaces in special applications.

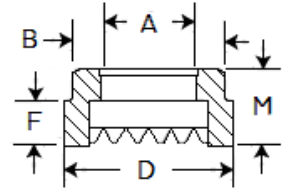

Low Profile

Nominal Stud Size	Inside Diameter A	Neck Diameter B	Major Diameter D	Height to Neck F	Height Overall M	Ferrule Part Number
1/2	0.500	0.785	0.875	0.125	0.281	100101115

Special Collar

Nominal Stud Size	Inside Diameter A	Neck Diameter B	Major Diameter D	Height to Neck F	Height Overall M	Ferrule Part Number
1/2-13	0.448	1.062	1.187	0.125	0.281	100101122
1/2-13	0.448	1.030	1.187	0.125	0.281	100101239
3/4-10	0.680	1.030	1.150	0.296	0.483	100101135

Special Short CFL, Full Threaded

Nominal Stud Size	Inside Diameter A	Neck Diameter B	Major Diameter D	Height to Neck F	Height Overall M	Ferrule Part Number
3/8-16	0.375	0.505	0.615	0.132	0.250	100101083

Non-Skid, Heavy Duty

Nominal Stud Size	Inside Diameter A	Neck Diameter B	Major Diameter D	Height to Neck F	Height Overall M	Ferrule Part Number
5/16	0.312	0.650	0.795	0.228	0.390	100101184
1/2-13	0.448	0.785	0.905	0.114	0.362	100101202

Short, Heavy Duty

Nominal Stud Size	Inside Diameter A	Neck Diameter B	Major Diameter D	Height to Neck F	Height Overall M	Ferrule Part Number
3/8	0.375	0.650	0.795	0.125	0.250	100101225

3/4 Special, Small Vent

Nominal Stud Size	Inside Diameter A	Neck Diameter B	Major Diameter D	Height to Neck F	Height Overall M	Ferrule Part Number
3/4	0.750	1.030	1.215	0.469	0.656	100101232

Special

Nominal Stud Size	Inside Diameter A	Neck Diameter B	Major Diameter D	Height to Neck F	Height Overall M	Ferrule Part Number
10 ga.	0.134	0.260	0.260	0.385	0.385	100101233

To determine the ferrule grips, ferrule holders, or ferrule tubes that can be used with specific ferrule types, look at the neck diameter (inside diameter) of the ferrule, then look in the accessories catalog for ferrule grips, holders, or tubes to match that inside diameter.

Ferrules

Special Applications

NELSON STUD WELDING SPECIFICATION

Special Ferrule for Welding at an Angle to a Base Plate

Studs need to be welded at an angle on embedment plates. Special ferrules are used to prevent binding in the neck of the ferrule, and to achieve consistent results.

45° welding requires the use of a fixture or stop to prevent the ferrules from moving during the weld cycle. Heavy-duty guns need to be used to get sufficient gun travel. When the plunge is being taken up, the gun must be manually retracted to prevent binding and breaking of ferrules.

The ferrule grip listed below for the 3/8" studs at 23° angles is not a split grip. The ferrule grips for 3/8" and 1/2" studs at 45° angles are special split grips. Split ferrule grips are essential when welding headed studs and they simplify loading of long **D2L** studs. The ferrule outside diameters listed below should be used when the fixtures or stops to prevent sliding are fabricated.

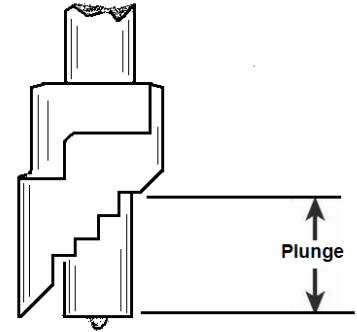

Stud Diameter A	Angle	Ferrule Neck Diameter B	Grip	Ferrule Part Number	Ferrule OD ¹
3/8	23	0.505	501008006	100104010	0.656
3/8	45	0.650	501009006	100104007	0.813
1/2	45	0.785	501009008	100104008	1.045

*Standard 3/8" grip #501-001-007 with ear bent out can also be used

¹ Ferrule OD clearance for stop or fixture.

Ferrules

Special Applications

NELSON STUD WELDING SPECIFICATION

Special Concave Ferrules for Welding to Curved Surfaces

For many applications, studs must be welded to the outside of curved surfaces of cylinders, tubes, pipes, or formed metal parts. In order to achieve good weld results when stud welding to a convex surface, the ferrule must fit both the stud diameter and the curve of the base material.

On the right is a partial listing of ferrules that Nelson can provide for welding to curved surfaces.

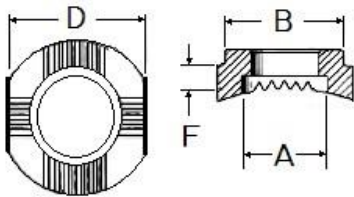

Standard Concave Ferrules						
Nominal Stud Size	Inside Diameter A	Weld Surface Curve Diameter	Effective Height F	Grip Neck Diameter B	Major Diameter D	Ferrule Part Number
1/4	0.250	3/8	0.380	0.380	0.555	100102005
5/16	0.312	3/8	0.250	0.505	0.595	100102054
0.33	0.330	1/2	0.303	0.585	0.703	100102051
3/8	0.375	3/4	0.235	0.785	0.875	100102093
3/8	0.375	7/8	0.312	0.505	0.585	100102012
3/8	0.375	7/8	0.437	0.505	0.640	100102046
3/8	0.375	1-3/4	0.343	0.505	0.640	100102091
3/8	0.375	3	0.343	0.505	0.640	100102092
1/2	0.500	1-1/4	0.312	0.785	0.875	100102025
1/2	0.500	1-5/8	0.437	0.650	0.806	100102023
1/2	0.500	3	0.437	0.650	0.806	100102019
1/2	0.500	3	0.437	0.785	0.875	100102021
1/2	0.500	3	0.680	0.650	0.796	100102081
1/2	0.500	3-1/2	0.250	1.615	1.615	100102090
1/2	0.500	3-1/2	0.312	0.921	1.125	100102026
0.59	0.590	1-7/8	0.493	0.785	1.030	100102082
5/8	0.625	3/4	0.495	0.785	1.030	100102095
5/8	0.625	1	0.515	0.785	1.030	100102029
5/8	0.625	2	0.495	0.785	1.030	100102030
5/8	0.625	2-5/8	0.340	1.615	1.615	100102085
5/8	0.625	4	0.320	1.615	1.615	100102096
5/8	0.625	4	0.515	0.785	1.030	100102032
5/8	0.625	3-3/4	0.340	1.615	1.615	100102084
0.68	0.680	1	0.437	1.030	1.140	100105007
3/4	0.750	2-9/16	0.532	1.030	1.187	100102038
7/8	0.875	3-3/4	0.465	1.615	1.615	100102086
1	1.000	3	0.813	1.406	1.615	100102087

Concave Ferrules for Reduced Base Studs*							
Nominal Stud Size	Inside Diameter A	Reduced Base Diameter	Weld Surface Curve Diameter	Effective Height F	Grip Neck Diameter B	Outer Diameter D	Ferrule Part Number
11/16	0.688	7/16	1-1/8	0.990	0.875	0.406	100102039
11/16	0.688	7/16	2	0.990	0.875	0.426	100102050
13/16	0.813	9/16	2	0.562	1.062	1.180	100102066
13/16	0.813	9/16	2-3/4	0.562	1.062	1.180	100102072

*Reduced weld base diameters are often needed on pipe and port fittings

Ferrules

Special Applications

NELSON STUD WELDING SPECIFICATION

Welding to Edges of Base Plates

Over the years, Nelson Stud Welding has developed several ferrules that permit welding of full base studs to the edges of plate or bars that are the same thickness as the stud diameter.

These ferrules are constructed with ears or tabs, which extend down over the sides of the base material, and with vents and a cavity that is limited to the base material thickness. Due to the limited base material width, the weld cavities are run along the edge for a distance greater than the normal flash diameter used for welding studs perpendicular to flat plates. This special ferrule design allows development of full stud strength when welding to the edges of plates or bars.

The neck diameters of the ferrules are shown to assist in the selection of ferrule tube, ferrule holders, and foot plates.

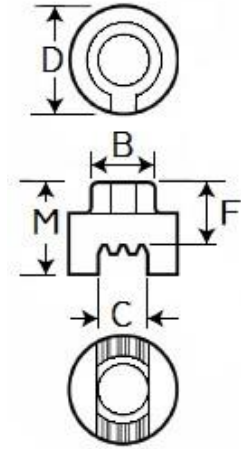

Stud Diameter A	Base Material Thickness C	Ferrule Neck Diameter B	Major Diameter D	Effective Height F	Overall Height M	Ferrule Part Number
1/4	1/4	0.380	0.555	0.468	0.468	100101223
3/8	3/8	0.650	0.795	0.562	0.577	100101204
1/2	1/2	0.785	1.030	0.625	0.640	100101205

The 3/8" and the 1/2" ferrules have standard necks, while the neck of the 1/4" ferrule has an orientation key on the neck. The key on the 1/4" ferrule requires either bending up one of the narrow gripping tines on the standard 1/4" ferrule grip, #501001005, or the use of a special 1/4" grip, #501008005, which has two notches in it to accept the key on the neck of the ferrule, as well as the two normal gripping tines.

The #100101223 ferrule has the orientation key because it was designed for use with a production unit, where the ferrule must be aligned with the base material. The 3/8" and 1/2" ferrules without the key on the neck were designed for use with hand held guns, where the gun can be turned to align the ferrule with the base material.

These ferrules are designed for use with Nelson full base diameter studs. This includes **H4L**, **S3L**, **D2L**, **NBL**, **TBL**, and other stud styles having full diameter weld bases.

Ferrules

Special Applications

NELSON STUD WELDING SPECIFICATION

Special Ferrule for Welding into Fillets and Onto Heels

The radius of the tip of these ferrules is important. The radius of the ferrules needs to match the radius on the angle to which the studs are to be welded in order to properly shield the weld arc and prevent the loss of metal.

If the radius inside the angle cannot be determined, it is better to select the ferrule with the larger radius since it is less detrimental to have a gap at the center of the angle than along both edges of the angle.

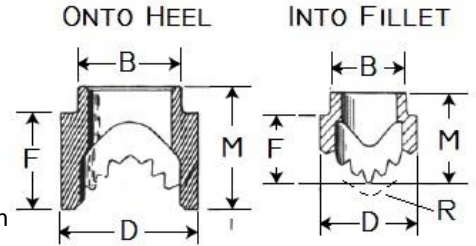

Into Fillet – inside corner of 90° angle

Stud Diameter A	Radius R	Neck Diameter B	Major Diameter D	Height to Neck F	Height Overall M	Ferrule Part Number	Split Ferrule Grips	
							2"	3"
1/4	0.125	0.380	0.578	0.350	0.500	100106001	501004003	501004010
3/8	0.250	0.505	0.640	0.375	0.480	100106002	501004006	501004011
1/2	0.375	0.650	0.795	0.500	0.688	100103011	501004008	501004013
5/8	0.375	0.785	1.030	0.687	0.875	100106005	501004009	—
1/2	0.250	0.650	0.687	0.795	0.500	100103009	501004008	501004013
3/4	0.750	1.030	1.218	0.687	0.875	100103012	501004014	—
3/4	0.375	1.030	1.218	0.562	0.937	100106004	501004014	—

Onto Heel – outside corner of 90° angle

Stud Diameter A	Neck Diameter B	Major Diameter D	Height to Neck F	Height Overall M	Ferrule Part Number	Split Grip
1/4	0.380	0.555	0.125	0.380	100102005	501003005
3/8	0.585	0.703	0.550	0.706	100105001	501003008
1/2	0.785	1.030	0.625	0.812	100105002	501003010
5/8	0.785	1.030	0.703	0.891	100105003	501003010
3/4	1.030	1.215	0.844	1.031	100105005	501003014

Ferrules

Special Applications

NELSON STUD WELDING SPECIFICATION

Special Ferrules for Stripping Straight Off Headed Studs

Welding of concrete anchors and shear connectors into holes through concrete, masonry, or wood, is a special application of Nelson studs. For these applications, a ferrule is needed with a neck diameter that is larger than the head on the stud. This allows the gun to be stripped straight off the welded studs.

The ferrules listed below have gripping neck diameters that are larger than the heads of the concrete anchors or shear anchors.

The 3/8" and 1/2" ferrules can also be used as Low Profile ferrules with special Collar studs that have full diameter weld bases.

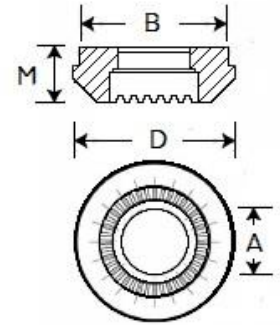

Stud Diameter A	Stud Head Diameter	Ferrule Gripping Neck Diameter* B	Major Diameter D	Overall Height M	Ferrule Part Number
3/8	0.750	0.785	0.875	0.281	100101101
1/2**	1.000	-	-	-	-
5/8	1.250	1.406	1.531	0.531	100101182
3/4	1.250	1.406	1.531	0.656	100101228
7/8	1.375	1.406	1.531	0.732	100101215

* The neck diameters of the ferrules are shown to assist in the selection of ferrule tube, ferrule holders, and foot plates.

** Due to lack of demand production of the straight strip-off ferrule for 1/2" headed studs has been discontinued. The 1/2" WTD ferrule, #100-101-237, has a neck diameter of 1.030" - so it can be used to strip straight off 1/2" diameter studs with 1" diameter head. The larger cavity and coarse vents of the #100-101-237 ferrule require hotter than normal weld settings.

Ferrules

Special Applications

NELSON STUD WELDING SPECIFICATION

Special Ferrules for Welding to Vertical Surfaces

When welding to a vertical surface, gravity causes molten metal to flow to the bottom side of the ferrule. There is an increased tendency toward metal loss through the ferrule vents, and it is more difficult to displace the metal to the top of the weld. This is important for the development of a full flash with no undercut produced.

On small diameters, vertical welding presents no real problem. The weld time is short, and there is not much molten metal produced.

However, because longer welding times are required to weld larger diameter studs, more molten metal is produced in the process. With more molten metal, welding to a vertical surface proves to be more difficult with a larger diameter stud. The use of standard ceramic ferrules resulted in poor weld flash formation on the “top side” of the weld fillet, and excessive metal loss out of the vents at the bottom of the ferrule.

Ferrules specifically designed for vertical plate stud welding have blocked vents at the bottom of the ferrule cavity and other features to prevent weld metal loss, and deposit more of the flash metal at the top of the weld.

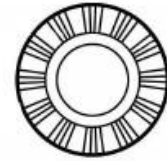
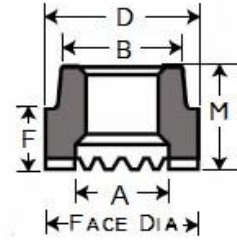

Stud Diameter A	Neck Diameter B	Major Diameter D	Height to Neck F	Height Overall M	Ferrule Part Number
0.500 and under	No Special Ferrule is Needed				
0.562	0.785	0.905	0.277	0.433	100101234
5/8	1.030	1.150	0.339	0.526	100101224
0.680	1.030	1.150	0.339	0.526	100101214
3/4	1.030	1.215	0.486	0.676	100101226
7/8	1.210	1.410	0.545	0.836	100101235

The neck diameters of the ferrules are shown to assist in the selection of ferrule tube, ferrule holders, and foot plates.

7/8" ferrule, #100101235, is not recommended since it may not always produce a full weld flash that will pass the AWS D1.1 360° Visual Inspection Test. If 7/8" studs are welded to vertical surfaces, the contractor should be prepared to repair the tops of the weld flash on studs that do not have the full 360° weld flash.

Ferrules

Special Applications

NELSON STUD WELDING SPECIFICATION

Special Ferrules for Welding Through metal Deck

Stud shear connectors, pioneered by Nelson Stud Welding, have been recognized for many years as the most efficient means of achieving the necessary interaction between steel beams and concrete slabs in composite construction. Studs were soon followed by metal deck as another upgrading of the composite approach.

Nelson completed the cycle by developing the equipment and ceramic ferrules to reliably weld shear connector studs to beams, through metal deck, cellular decks, and single decks, with commercial grade (1-1/4 oz. per square foot) galvanized coatings.

Benefits of Basic Design Upgraded by Metal Deck

The recognized advantages of composite beam construction are augmented, in many cases, through the use of metal deck. The composite beam consists of three elements: the steel beam, a reinforced concrete slab, and shear connector studs welded to the beam. The studs transfer horizontal shear from slab to beam, causing the two elements to act as a single unit. The strength and stiffness of the effective section are increased without using more steel.

Composite design permits savings in steel tonnage of up to 20%. It reduces building height and saves on materials because lighter beams result in shallower floor sections, and provides larger rooms with fewer obstructions because longer spans may be used. Although the advantages of metal deck may differ from job to job, the general benefits are so broad that deck can be recommended wholeheartedly. Here are some typical benefits:

- Metal deck provides a permanent form for concrete and eliminates the cost of wood forms and shoring costs.
- Less reinforcing steel is needed.
- Construction is faster because deck serves as a work platform for all trades.
- Electrical cables may be placed in cellular sections of deck.
- Suspended ceilings may cost less because it is simpler and faster to suspend them from metal deck than concrete.
- Metal deck stiffens the structure.
- A construction fire hazard is eliminated, usually resulting in more favorable insurance rates.

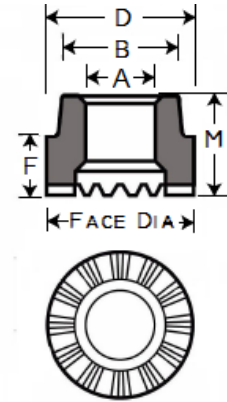

Stud Diameter A	Neck Diameter B	Major Diameter D	Height to Neck F	Height Overall M	Face Diameter	Ferrule Part Number
3/8	0.785	0.875	0.281	0.438	0.875	100101242
1/2	1.030	1.150	0.438	0.625	0.920/0.86	100101237**
5/8	1.030	1.203	0.437	0.625	1.218	100101203
3/4	1.210	1.330	0.406	0.593	1.345	100101175*
3/4	1.210	1.304	0.406	0.593	1.060/1.00	100101177**
3/4	1.210	1.410	0.497	0.674	1.435	100101181***

* Standard ferrule

** Chamfered for narrow valley decking - Chamfer less 0.030" radius both sides =Actual

*** Stud centering ribs in ferrule neck

The neck diameters of the ferrules are shown to assist in the selection of ferrule grips, ferrule holders, and foot plates.

For information on the studs that are used with this process, see Nelson [H4L Concrete Anchor](#) and [S3L Shear Connector studs](#).

Note: Welding through metal deck is an application very dependent upon job site conditions and must be application qualified according to site conditions, metal deck thickness, amount of galvanizing on the deck, etc. Consult your Nelson Sales Representative for appropriate use of the ferrules shown and application details. Also consult guidelines and restrictions on through deck welding as shown in *AWS D1.1 Structural Welding Code – Steel* and *American Institute of Steel Construction Allowable Strength Design* and/or *Load & Resistance Factor Design* manuals of steel construction.

Ferrules

NELSON STUD WELDING SPECIFICATION

Rectangular Ferrules

The rectangular ferrules shown below are used to weld the following stud types: **R1P and R1L Rectangular Studs without Holes**, **R2P Two Tine Rectangular Studs**, **R5P Strand Support Studs**, **R6P Rectangular Slotted Stud**, **R7P Rectangular Stud with Hole**, **RWP Stud**, **RXX FiberLok Stud**, and other applications where rectangular studs are being applied to flat surfaces.

Standard Rectangular Ferrule

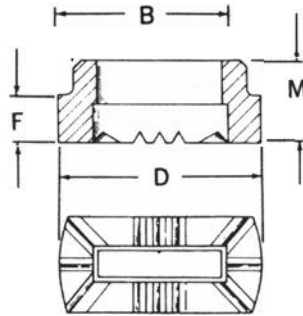

No Neck Rectangular Ferrule

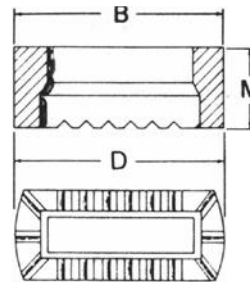

Stud Thickness	Stud Width	Neck Diameter B	Width	Major Diameter D	Height to Neck F	Height Overall M	Ferrule Grip or Foot	Ferrule Part Number
1/8	1/4	0.445	Round	0.578	0.234	0.390	501003006	100301014
1/8	3/8	0.505	Round	0.640	0.234	0.390	501001007	100301002
1/8	5/8	0.921	0.562	1.093	0.234	0.438	501001012*	100301003
1/8	5/8	0.921	0.320	1.093	0.234	0.375	501001012*	100301004
1/8	5/8	0.437	0.562	1.093	0.250	0.406	503003000	100301005
1/8	5/8	0.921	Round	1.020	0.205	0.375	501001012*	100301015
3/16	5/8	0.437	0.562	1.093	0.250	0.406	503003000	100301007
3/16	3/4	0.921	0.562	1.156	0.281	0.437	501001012*	100301006
1/4	5/8	0.500	0.625	1.093	0.250	0.406	503003000	100301021
1/4	1	1.210	0.625	1.406	0.281	0.437	501001015	100301010
1/4	1-1/4	1.812	0.750	1.812	no neck	0.672	503001000	100301012
3/8	1	1.610	0.750	1.610	no neck	0.437	503022000	100301023

* Ferrules with 0.921" neck may be welded with #501001012 ferrule grip, as shown, or depending on the stud shape, a ferrule foot plate #501006011, may be needed

Ferrules

NELSON STUD WELDING SPECIFICATION

Double Reduced Base Studs

These ferrules have an internal cavity, and are used to weld studs that have a base diameter that is significantly smaller than the outer diameter of the stud. This combination of stud and ferrule results in a weld flash diameter that is smaller than the stud diameter. Double reduced weld base studs may be used in applications where the base material thickness is too thin for welding the full stud diameter without burning through the base material.

The ferrules may also be used with short studs that serve as locator, or “dowel pin,” studs, where having a small weld flash is of more importance than the weld strength.

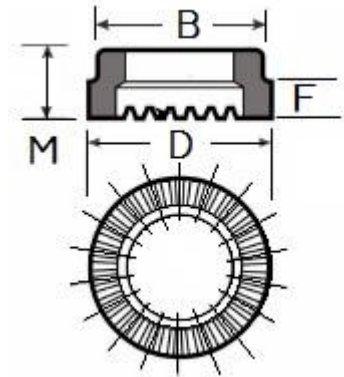

Stud Diameter (Outer)	Weld Base	Neck Diameter B	Major Diameter D	Height to Neck F	Height Overall M	Ferrule Grip	Ferrule Part Number
3/4	7/16	0.990	0.990	No neck	0.406	501010019	100107002
5/8	7/16	0.990	0.990	No neck	0.406	501010019	100108008
3/4	1/2	1.100	1.100	No neck	0.500	501010053	100108019
5/8	7/16	1.100	1.250	0.156	0.406	501010053	100108020
5/8	7/16	0.921	1.030	0.218	0.406	501001012	100108022

Ferrules

NELSON STUD WELDING SPECIFICATION

Refractory Anchor Ferrules

S7X 3/16" "Steerhorn" and **S4X** "Y" Anchor refractory anchor studs have a special weld end shape. The weld ends of these studs are made by doubling the stud back on itself. These weld bases require a special ferrule to fit this weld base.

These ferrules are designed for welding of Nelson **S4X** and **S7X** style refractory anchor studs.

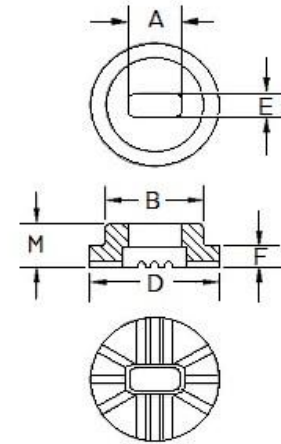

Stud Diameter	Neck Diameter B	Major Diameter D	Height to Neck F	Height Overall M	Inside Length A	Inside Width E	Ferrule Foot Plate	Ferrule Part Number
2 x 3/16" dia.	0.785	1.030	0.171	0.360	0.430	0.200	501006018	100101170
2 x 1/4" dia.	0.785	1.030	0.218	0.468	0.580	0.285	501006018	100101127

Accessories

Chucks

NELSON STUD WELDING SPECIFICATION

Stud Weld Gun Imperial Dimension Chucks

Below is a list of standard imperial chucks for use in welding Nelson studs. The chucks are listed with both imperial and metric dimensions so that the difference in size between two chucks can be easily compared. This will indicate if the stud will be tight or loose in an alternative chuck. The lengths given are the overall chuck lengths.

Chucks for use with Standard Stud Weld Guns

Chuck Description	Stud Diameter		L Length (inches)	Chuck Part Number	Type
	Imperial Dimension (inches)	Metric Dimension (mm)			
#4	0.112	2.84	2-5/8	500001135	1
1/8" and 11 ga.	0.125	3.17	2-5/8	500001001	
#6 and 10 ga.	0.134	3.40	2-5/8	500001002	
5/32	0.156	3.96	2-5/8	500001003	
#8 and 8 ga.	0.164	4.17	2-5/8	500001006	
3/16" and #10	0.187	4.76	2-5/8	500001005	
7/32 and 1/4-20 pitch	0.218	5.54	2-5/8	500001004	
1/4	0.250	6.35	2-1/4	500001007	2
5/16-18 pitch	0.275	6.98	2-1/4	500001008	
5/16	0.312	7.92	2-1/4	500001009	
3/8-16 pitch	0.330	8.38	2-1/4	500001010	
3/8	0.375	9.53	2-1/4	500001011	
7/16	0.437	11.10	2-1/4	500001012	
1/2-13 pitch	0.448	11.38	2-1/4	500001013	
1/2	0.500	12.70	2-1/2	500001014	3
9/16 and 5/8-11 pitch	0.562	14.27	2-1/2	500001015	
5/8	0.625	15.87	3	500001016	
3/4-10 pitch and 11/16	0.680	17.27	3	500001245	
3/4	0.750	19.05	3	500001018	
7/8	0.875	22.23	3	500001019	

#2 Morse Taper Mounting

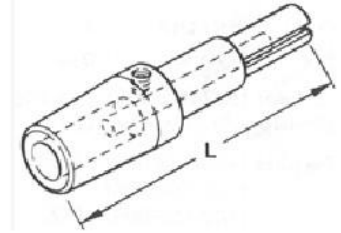

Standard Length Adjustable Depth Chuck
Type 1

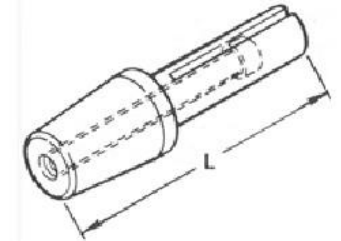

Standard Length Adjustable Depth Chuck
Type 2

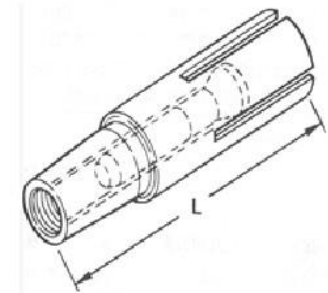

Standard Length Adjustable Depth Chuck
Type 3

Accessories

Chucks

NELSON STUD WELDING SPECIFICATION

Stud Weld Gun Imperial Dimension Chucks (Continued)

Chucks for use with Standard Stud Weld Guns (Continued)

Chuck Description	Stud Diameter		L Length (inches)	Chuck Part Number	Type
	Imperial Dimension (inches)	Metric Dimension (mm)			
1 Assembly	1.000	25.40	3-5/8	500001085	4
A 1 Body				500001110	
B 1 Sleeve				500000111	
1-1/8 Assembly	1.125	28.57	3-5/8	500001086	
A 1-1/8 Body				500001113	
B 1-1/8 Sleeve				500001114	
1-1/4 Assembly	1.250	31.75	3-5/8	500001088	5
A 1-1/4 Body				500001117	
A 1-1/4 Sleeve				500001118	
1-3/8 Assembly	1.375	34.93	3-5/8	500001091	
A 1-3/8 Body				500001121	
A 1-3/8 Sleeve				500001120	
1-1/2 Assembly	1.500	38.10	3-5/8	500001093	
A 1-1/2 Body				500001123	
A 1-1/2 Sleeve				500001124	
1-5/8 Assembly	1.625	41.27	3-5/8	500001424	
A 1-5/8 Body				500001425	
A 1-5/8 Sleeve				500001426	
1-3/4 Assembly	1.750	44.45	3-5/8	500001095	
A 1-3/4 Body				500001115	
A 1-3/4 Sleeve				500001116	

**Type 4
#2 Morse Taper Mounting**

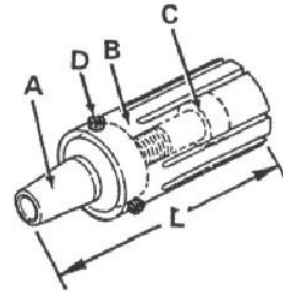

**Standard Length Adjustable
Depth Chuck
Type 4**

**Type 5
1/2-20 Thread Mounting**

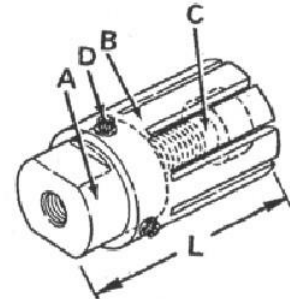

**Standard Length Adjustable Depth
Chuck
Type 5**

Accessories

Chucks

NELSON STUD WELDING SPECIFICATION

Stud Weld Gun Metric Dimension Chucks

Stud Diameter		L Length (inches)	Chuck Part Number	Type
Metric Dimension (mm)	Imperial Dimension (inches)			
2	0.079	2-5/8	500001342	1
3	0.118	2-5/8	500001135	
4	0.157	2-5/8	500001003	
5	0.198	2-5/8	500001427	
6	0.236	2-1/4	500001267	2
8	0.315	2-1/4	500001009	
9	0.354	2-1/2	500001434	
10	0.394	2-1/4	500001269	
12	0.472	2-1/2	500001206	
14	0.551	2-1/2	500001391	
16	0.630	3	500001016	3
18	0.708	2-1/2	500001271	
19	0.748	3	500001018	
20	0.787	2-1/2	500001272	
22	0.866	2-1/2	500001019	
24 Assembly	0.944	3-5/8	500001085	
A 24 Body			500001110	4
A 24 Sleeve			500001111	
25 Assembly	0.984	3-1/4	500001085	
A 25 Body			500001110	5
A 25 Sleeve			500001111	
22 (one piece)	0.866	3-1/2	500001485	
29 Assembly	1.142	3-5/8	500001481	5
A 29 Body			500001113	
A 29 Sleeve			500001482	
32 Assembly	1.260	3-1/2	500001483	5
A 32 Body			500001117	
A 32 Sleeve			500001484	
35 Assembly	1.378	3-5/8	500001091	5
A 35 Body			500001121	
A 35 Sleeve			500001120	
40 Assembly	1.575	3-5/8	500001433	5
A 40 Body			500001425	
A 40 Sleeve			500001426	

To the left is a list of standard metric chucks to be used when welding Nelson studs. The chucks are listed with both metric and imperial dimensions so that the difference in size between two chucks can be easily compared. This will indicate if the stud will be tight or loose in an alternative chuck. The lengths given are the overall chuck lengths.

Standard Metric Chucks for use with Standard Stud Weld Guns

Types 1-4

#2 Morse Taper Mounting

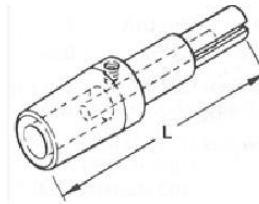

Standard Length Adjustable Depth Chuck
Type 1

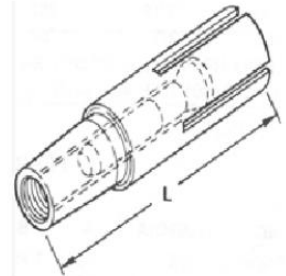

Standard Length Adjustable Depth Chuck
Type 3

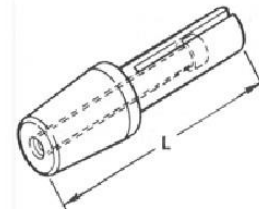

Standard Length Adjustable Depth Chuck
Type 2

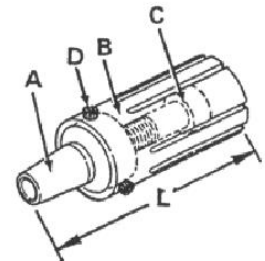

Standard Length Adjustable Depth Chuck
Type 4

Type 5

1/2-20 Thread Mounting

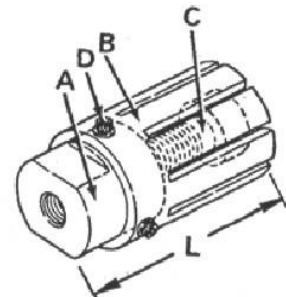

Standard Length Adjustable Depth Chuck
Type 5

Accessories

Chucks

NELSON STUD WELDING SPECIFICATION

Long Style Chucks

Nelson long style chucks are typically used when more accessory length is needed. This occurs when short studs are welded through fixtures, templates, or through holes in materials like wood, plastic, or steel. Often, long style studs are used when ferrule tubing holds ferrules, during welding, in place of standard ferrule grips.

3-7/8" Long Style Chucks with Adjustable Depth Stop

Chuck Description	Stud Diameter		Chuck Part Number
	Imperial Dimension (inches)	Metric Dimension (mm)	
#8	0.164	4.17	500001221
#10	0.187	4.76	500001220
1/4	0.250	6.35	500001028
5/16	0.312	7.92	500001029
3/8	0.375	9.53	500001030
7/16	0.437	11.10	500001031
1/2	0.500	12.70	500001032
M6	0.236	6.00	500001332
M10	0.394	10.00	500001334
M12	0.472	12.00	500001336

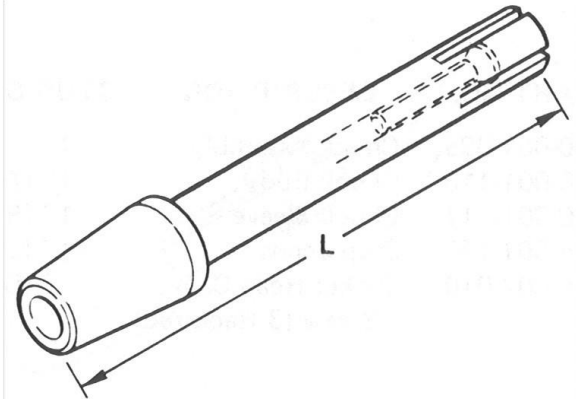

3-7/8" Long Length Straight Style Adjustable Depth Chuck

4-3/4" Long Straight Style Chucks (Fixed Chuck Depth is 1/2")

Chuck Description	Stud Diameter		Chuck Part Number
	Imperial Dimension (inches)	Metric Dimension (mm)	
#6	0.138	3.51	500001036
#8	0.164	4.17	500001037
#10	0.190	4.83	500001038
1/4	0.250	6.35	500001039
5/16	0.312	7.92	500001040
3/8	0.375	9.53	500001041
7/16	0.437	11.10	500001042
1/2	0.500	12.70	500001043
5/8	0.625	15.87	500001044
3/4	0.750	19.05	500001045
7/8	0.875	22.23	500001046

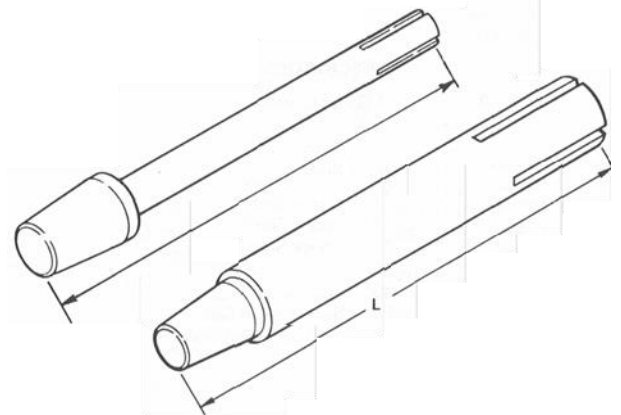

4-3/4" Long Length Fixed Chuck Depth (1/2") Chucks

Accessories

Chucks

NELSON STUD WELDING SPECIFICATION

Male Style and Extensions

Male Style 2-1/2" Long Chucks for Welding Internally Tapped Studs

Chuck Description	Length of Extension	Chuck Part Number
#10-24	0.218	500003003
#10-24	0.375	500003004
#10-32	0.375	500003005
1/4-20	0.375	500003008
5/16-18	0.375	500003010
3/8-16	0.375	500003014
7/16-14	0.218	500003016
1/2-13	0.500	500003017
5/8-11	0.625	500003018
3/4-10	0.625	500003019

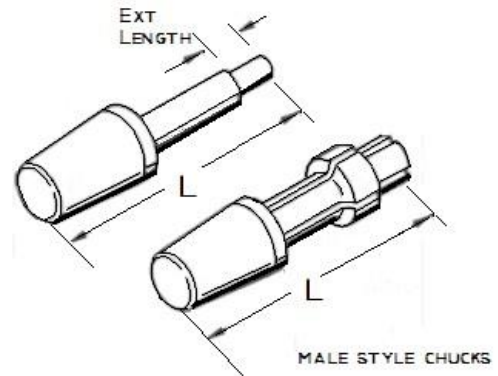

Chuck Adapter with Male Style Chucks
#2 Morse Taper with Internal Hole and Set Screws

Chuck Description	Chuck Part Number
3/16" diameter hole	521001030
1/4" diameter hole	521001014
3/8" diameter hole	521001023

Male Style Chucks for Welding Studs with Unthreaded Holes

Chuck Description	Length of Extension	Chuck Part Number
3/16	3/16	500003007
3/16	7/32	500003042
3/16	3/8	500003006
1/4	3/16	500003057
1/4	7/32	500003012
1/4	5/16	500003053
3/8	3/8	500003058

Adapter for Male Style Chucks
#521-001-030, #521-001-014 and #521-001-023

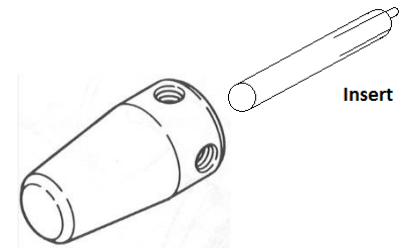

Male Insert Style Chucks for Use with Chuck Adapters

Chuck Description (Hole Diameter)	Length of Extension	Chuck Insert	Adapter Part Number
0.080	0.066	500003001	521001030
0.140	1/8	500001002	521001014
1/8	1/4	500003028	521001014
3/16	3/8	500003021	521001014
1/4	No Shoulder	500003045	521001014

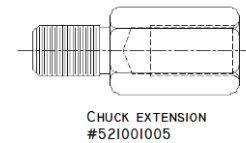

Chuck Extensions – Add 1-1/2" to Length of Chuck Assembly
1/2-20 External and Internal Thread with Lock Nut

Chuck Description (Overall Length)	Length of Threads	Extension Part Number
3/4 hex x (2 x Overall Length)	0.750	521001005

Chuck Extensions
#2 Morse Taper and External Thread

Chuck Description (Overall Length)	Length of Threads	Chuck Part Number
3/8-24 x 3.750 (2 x Overall Length)	0.375	521001016
1/2-20 x 1.500	0.750	521001004

Accessories

Chucks

NELSON STUD WELDING SPECIFICATION

Rectangular, Square, Internal, Bent, and Side Gripping

Rectangular Chucks Morse Taper Mounting

Chuck Description	Chuck Part Number
1/8 x 1/4	500005118 (for Fiber-Lok)
1/8 x 3/8	500005003
1/8 x 5/8	500005014
1/8 x 3/4	500005021
1/8 x 7/8	500005005
1/8 x 1	500005006
1/8 x 1-1/2	500005059
3/16 x 3/4	500005007
3/16 x 7/8	500005008
3/16 x 1	500005009
3/16 x 1-1/4	500005011
1/4 x 1/2	500005092
1/4 x 3/4	500005010
1/4 x 1	500005012
1/4 x 1-1/4	500005019
3/8 x 1	500005101

90° Bent Style Stud Chucks 1/2-20 Internal Thread Mounting

Chuck	Chuck Part Number
1/8	500008001 or 500008002
3/16	500008004
1/4	500008005
5/16	500008006
3/8	500008007
7/16	500008009
1/2	500008010
9/16	500008011
5/8	500008012
3/4	500008013
7/8	500008014

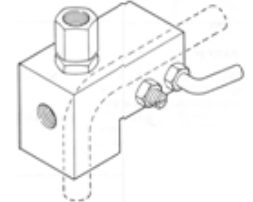
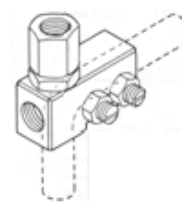

90° Bent Style Chucks with 1/2-20 Internal Thread Mounting
Left: Chuck for studs 1/8 through 7/16"

45° Bent Style Stud Chucks Morse Taper Mounting

Chuck Description	Chuck Part Number
3/8	500010002
1/2	500010008
5/8	500010010
3/4	500010016
7/8	500010037

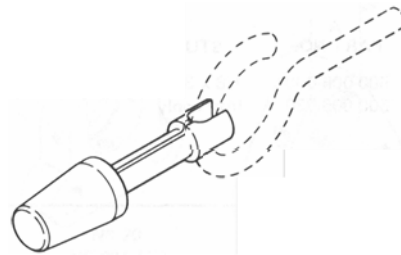

Eyebolt Style Chucks

Internal Morse Taper Adapter with Internal Threads

Thread	Length	Part Number
1/2-20	1-7/8	751004029

Eyebolt Style Chucks

Morse Taper Mounting

Chuck Description	Chuck Part Number
3/16	500011002
1/4	500011003
5/16	500011004
3/8	500011005
7/16	500011006
1/2	500011007

Square Chucks

1/2-20 Internal Thread Mounting

Chuck Description	Chuck Part Number
3/4	500007035
7/8	500007037
1-1/8	500007039

Side Gripping Chuck Assemblies (LEGACY)

Chuck Description	Chuck Part Number
1/4	500014103
3/8	500014102
1/2	500014095
5/8	500014096
3/4	500014097
7/8	500014101

Nelson Side Gripping chucks have two ball detents and a screw lever to grip the studs. Chuck adapter offset, #500014088, and other parts are needed to mount these chucks on the stud welding gun.

Alternate side gripping chuck designs are available. See [PSR Studs](#)

Accessories

Chucks

NELSON STUD WELDING SPECIFICATION

Capacitor Discharge Weld Gun Chucks

Standard and Metric Capacitor Discharge Stud Welding Chucks for Use with NCD and NCD+ Stud Welding Guns

Chuck Description 3/8" O.D.	Stud Diameter		Length (inches)	Chuck Part Number
	Imperial Dimension (inches)	Metric Dimension (mm)		
13ga.	0.095	2.41	2-3/8	500001374
12ga.	0.109	2.77	2-3/8	500001363
0.118 and #4 threaded	0.112	2.84	2-3/8	500001355
1/8 and #5 threaded	0.125	3.17	2-3/8	500001390
10ga. and #6 threaded	0.134	3.40	2-3/8	500001356
M4	0.157	3.99	2-3/8	500001361
#8 threaded	0.164	4.17	2-3/8	500001357
3/16 Annular Ring	0.178	4.75	2-3/8	500001373
3/16" and #10 threaded	0.190	4.83	2-3/8	500001366
M5	0.197	5.00	2-3/8	500001358
M6	0.236	6.00	2-3/8	500001362
1/4	0.250	6.35	2-3/8	500001359
M7	0.275	7.00	2-3/8	500001368
5/16 and M8	0.312	7.92	2-3/8	500001360
3/8	0.375	9.53	2-3/8	500001369
M10	0.394	10.00	2 3/8	500001369

Stud Stop Pin Assembly for NCD and NCD+ Stud Welding Guns

Stud Length (inches)	Part Number
1/4 to 5/8	500017017
3/4 to 1-1/8	500017018
1-1/4 to 1-5/8	500017019
1-3/4 to 2-1/8	500017020
Pencil Gun	500017063

Note: NCD and CD Lite chucks are NOT interchangeable due to the difference in the 3/8" and 10mm outside diameter of these chucks

Standard Capacitor Discharge Stud Welding Chucks for use with CD Lite-G and CD Lite-C Stud Welding Guns for Welding 1/4 to 1-1/2" (6 to 40mm) long studs*

Chuck Description 10mm O.D.	Stud Diameter		Length inches (mm)	Chuck Assembly Part Number
	Imperial Dimension (inches)	Metric Dimension (mm)		
#4 & 12 ga	0.112	2.84	1-3/4 (45)	500001515
M3	0.118	3.00	1-3/4 (45)	500001510
#6 & 10 ga	0.134	3.40	1-3/4 (45)	500001516
M4	0.157	4.00	1-3/4 (45)	500001511
#8	0.164	4.17	1-3/4 (45)	500001517
M5	0.198	5.00	1-3/4 (45)	500001512
#10 & 3/16	0.190	4.83	1-3/4 (45)	500001518
M6	0.236	6.00	1-3/4 (45)	500001513
1/4	0.250	6.35	1-3/4 (45)	500001519
5/16 & M8	0.312	7.92	1-3/4 (45)	500001520

*Welding of studs longer than 1-1/2" (40mm), or through a template, requires special accessories

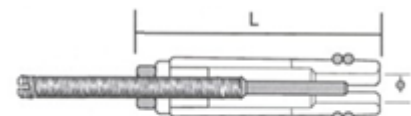

CHUCK AND STOP ASSEMBLY
CD-Lite-G and CD-Lite-C Chuck

Accessories

Chucks

NELSON STUD WELDING SPECIFICATION

Screw-On Chucks and Extensions to Reach into Ferrule Tubing & Holes

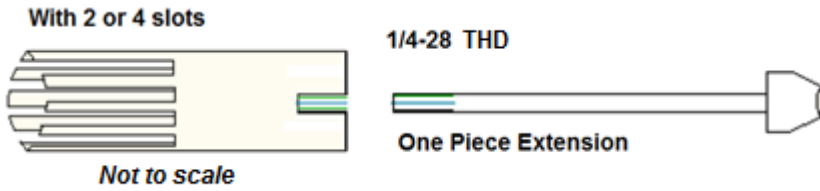

Chucks with 1/4"-28 Internal Thread			
Stud Size	Diameter (inches)	Part #	Length
#8	0.164	500001077	3-5/8"
#10 & 3/16"	0.187	500001142	1-1/4"
1/4"	0.250	500001079	2-1/2"
5/16"	0.312	500001080	2-1/2"

Morse Taper with 1/4"-28 Thread	
Length	Part #
3-1/4"	521001040
4-3/4"	521001063
5-1/2"	521001051
8"	521001049

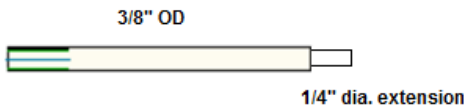

Bar with 1/4"-28 Thread	
Length	Part #
3-3/4"	521001021

Taper with Hole for 1/4" Bars	
Part #	
521001014	



Chucks with 3/8"-24 Internal Thread			
Stud Size	Diameter (inches)	Part #	Length
1/8"	0.125	500007179	2-1/2"
#6	0.132	500001144	2-1/2"
#8	0.164	500001145	2-1/2"
#10 & 3/16"	0.187	500001146	2-1/2"
1/4"	0.250	500001147	2-1/2"
5/16"	0.312	500001190	3-1/4"
3/8"	0.375	500001131	2-1/2"
1/2"	0.500	500001083	2-1/2"
5/8" & 3/4"	None needed: The Chuck Stop Threads are 3/8"-16 (no part number) custom made with Taper Adaptor #521-001-023		

Morse Taper with 3/8"-24 Thread	
Length	Part #
1-3/8"	521001056
3-1/2"	521001016
10-3/16"	521001039
21-1/2"	521001046



Bar with 3/8-24 Thread		Taper with Hole for 3/8" Bars	
Length	Part #	Part #	
3-3/4"	521001073	521001023	
10"	521001089		



Accessories

Feet

NELSON STUD WELDING SPECIFICATION

Standard feet are made of an insulating material. They are mounted on the two legs that extend from the gun body. A ferrule grip, ferrule holder, or spark shield is then installed on the foot.

The foot is adjusted and locked so that a portion of the stud extends beyond the ferrule or spark shield. This portion of the stud is available to be melted during the welding process to create the weld flash surrounding the welded stud. The foot and leg assembly is locked into position by set screws in the gun body that tighten against the legs. When the gun is positioned to make a weld, the spark shield or ferrule contacts the base material and provides a reference for the lift and plunge of the stud during the weld cycle.

In order to properly fit the feet to the ferrule and ferrule grip, please consult the chart below.

Foot Size	Nominal Ferrule Size		Ferrule Neck Diameter	
	Minimum	Maximum	Minimum	Maximum
Small	1/8	1/2	0.281	0.650
Medium	5/8	3/4	0.785	1.030
Large	7/8	1	1.210	1.406

Different feet may be needed for various stud welding applications. Please consult the charts below for different feet styles.

Standard Closed Feet

Gun Description	Small A=0.875	Medium A=1.156	Large A=1.750
NS-20	502001001	502001002	502001003
NS-20A-HD	502001001	502001002	502001003
NS-30	502001137	502001138	502001144
NS-40	502001137	502001138	502001144

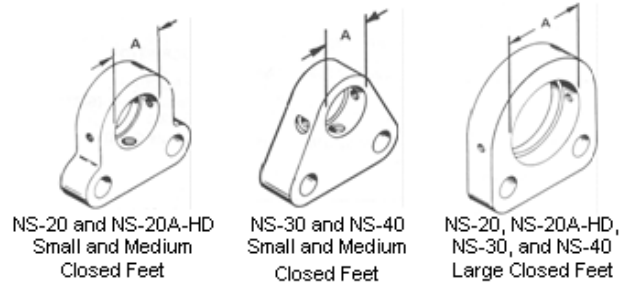

Standard Split or Open Feet

Gun Description	Small A=0.875	Medium A=1.156	Large A=1.750
NS-20	502002001	502002002	N/A
NS-20A-HD	502002001	502002002	502002003
NS-30	502002045	502002046	N/A
NS-40	502002045	502002046	N/A

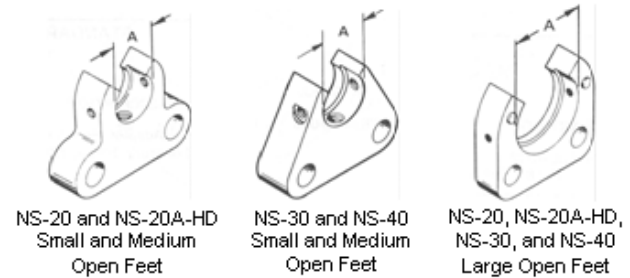

Shear Connector and Gas Feet

Gun Description	Standard Shear Connector Foot ¹ A=1.750	Shear Connector Bipod Foot ^{1,2}	Gas Adapter Feet ³
NS-20	N/A	N/A	751020000
NS-20A-HD	502002009	503000000	N/A
NS-30	N/A	503019000	751020000
NS-40	N/A	503019000	751020000

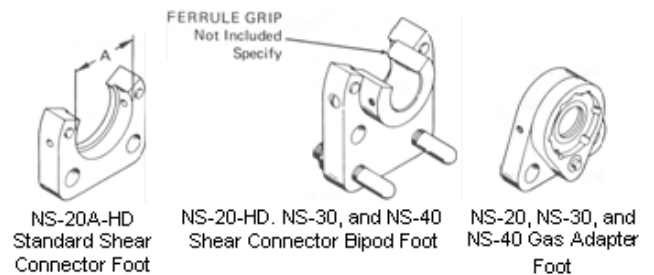

1 Use with Shear Connector Ferrules Grips
 2 NS-20A-HD: for ferrules 1/2" diameter and larger
 NS-30 and NS-40: for ferrules 3/8" diameter and smaller
 3 For studs 3/16" through 1/2"

Accessories

Ferrule Grips and Ferrule Holders

NELSON STUD WELDING SPECIFICATION

Ceramic ferrules, an essential part of the stud welding process, can be positioned on the front of the stud welding gun using several different styles of ferrule grips or ferrule holders.

Standard ferrule grips are used for most studs. Split ferrule grips are used for long studs, and for studs that have heads larger than the stud base diameter. Shear Connector grips and the Weld Through Metal Deck ferrule holders are used in construction applications. Ferrule tubes are used for welding through holes in wood, plastic, or masonry.

The neck diameter of the ferrule is the primary dimension needed when selecting the appropriate ferrule grip or ferrule holder. Below is a chart showing the various ferrule grips, ferrule holders, and ferrule tubing needed for ferrules with different neck diameters.

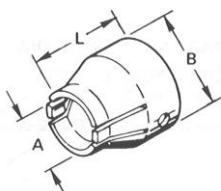

Standard Ferrule Grip

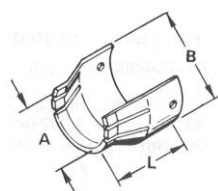

Split Ferrule Grip

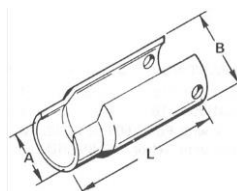

Long Length Ferrule Grip



Ferrule Foot Plate

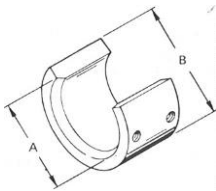

Shear Connector Ferrule Grip

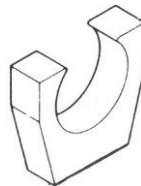

Weld Through Deck Ferrule Holder

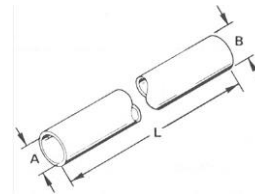

Ferrule Tubing

Small Copper Ferrule Grips

Fits in Standard "Small" Feet

Major Diameter: 0.875"

Neck Diameter of Ferrule	Nominal Size	Standard Ferrule Grip	Standard Split Ferrule Grip	Long Length Split Ferrule Grip	Ferrule Foot Plate	Shear Connector Grip ¹	Weld Through Deck Ferrule Holder ²	Ferrule Tubing
0.281	#6	501001002	501003001	N/A	N/A	N/A	N/A	N/A
0.291	#8	501001003	501003002	N/A	N/A	N/A	N/A	501005001
0.305	#10	501001004	501003003	N/A	501006010	N/A	N/A	501005002
0.380	1/4*	501001005	501003005	501004003	501006001	N/A	N/A	501005003
0.445	5/16	501001006	501003006	501004005	501006002	N/A	N/A	501005004
0.505	3/8*	501001007	501003007	501004006	501006003	N/A	501006050	501005005
0.585	7/16	501001008	501003008	501004007	501006004	N/A	N/A	501005006
0.650	1/2*	501001009	501003009	501004008	501006005	501003022	501006039	501005007

¹ Shear Connector ferrule grips are for use in Standard Shear Connector foot #502002009; Shear Connector Bipod Foot #503000000, or Standard Large Feet, #502001144, for NS-30 and NS-40 guns, or #502001003 for NS-20 and Heavy Duty guns.

² Weld Through Deck ferrule Holders are for use on WTD Foot extension Assembly, #502002042.

NOTE: The ferrules supplied for unthreaded 1/4", 3/8", 1/2", and 5/8" diameter studs have neck diameters that are for 1/8" larger ferrules than the standard. This applies to NBL, H4L, HBL, SBL, and D2L studs.

Accessories

Ferrule Grips and Ferrule Holders NELSON STUD WELDING SPECIFICATION

Medium Copper Ferrule Grips

Fits in Standard "Medium" Feet

Major Diameter: 1.156"

Neck Diameter of Ferrule	Nominal Size	Standard Ferrule Grip	Standard Split Ferrule Grip	Long Length Split Ferrule Grip	Ferrule Foot Plate	Shear Connector Grip ¹	Weld Through Deck Ferrule Holder ²	Ferrule Tubing
0.785	5/8	501001011	501003010	501004009	501006007	501003021	501006044	501005008
0.921	3/4 Special	501001012	501003011	N/A	501006011	N/A	N/A	N/A
1.030	3/4	501001014	501003014	501004014	501006008	501003019	501006027	501005009

Larger Copper Ferrule Grips

Fits in Standard "Large" Feet

Major Diameter: 1.750

Neck Diameter of Ferrule	Nominal Size	Standard Ferrule Grip	Standard Split Ferrule Grip	Long Length Split Ferrule Grip	Ferrule Foot Plate	Shear Connector Grip ¹	Weld Through Deck Ferrule Holder ²	Ferrule Tubing
1.210	7/8	501001015	501003015	N/A	501006009	501003020	501006028	N/A
1.406	1	501001016	501003016	N/A	501006032	501003025	501006046	N/A

¹ Shear Connector ferrule grips are for use in Standard Shear Connector foot #502002009 or Shear Connector Bipod Foot #503000000 on Heavy Duty guns.

² Weld Through Deck ferrule Holders are for use on WTD Foot extension Assembly, #502002042.

NOTE: The ferrules supplied for unthreaded 1/4", 3/8", 1/2", and 5/8" diameter studs have neck diameters that are for 1/8 larger ferrules than the standard. This applies to NBL, H4L, HBL, SBL, and D2L studs.

Accessories

Miscellaneous Stud Welding Accessories

NELSON STUD WELDING SPECIFICATION

S4X and S7X Refractory Anchor Accessories

Part Description	Part Number
Chuck	500015073
Ferrule Foot Plate	501006018

Pipe Hanger Assemblies (Clip Stud 101084029)

Part Description	Part Number
Chuck	500005061
Foot-Grip Assembly	503022000

Ferrule Foot Plates

Stud Diameter	Grid Opening A	Part Number
1/4	0.380	501006001
5/16	0.445	501006002
3/8	0.505	501006003
7/16	0.585	501006004
1/2	0.650	501006005
5/8	0.785	501006006
3/4	1.030	501006007
7/8	1.210	501006008

Weld Through Deck Accessories

Part Description	Inside Diameter	Part Number
Foot Extension Assembly	-	502002042
3" Foot Extension	-	502002044
Foot	-	502002043
Ferrule Holder (1/4-3/8")	0.505	501006050
Ferrule Holder (3/8-1/2")	0.650	501006039
Ferrule Holder (1/2-5/8")	0.785	501006044
Ferrule Holder (5/8-3/4")	1.030	501006027
Ferrule Holder (3/4-7/8")	1.210	501006028
Ferrule Holder (7/8-1")	1.406	501006046

Shear Connector Ferrule Grips

Stud Diameter	Inside Diameter A	Outside Diameter B	Part Number
1/2	0.650	1.750	501003022
5/8	0.785	1.750	501003021
3/4	1.030	1.750	501003019
7/8	1.210	1.750	501003020
1	1.406	1.750	501003023

NS-20 or NS-20A HD legs – 3/8" Leg Diameter

Part Description	Stud Length	Stud Length for Gun with Tranquil Arc	Part Number
Adjustable 9" leg	Less than 4-1/2"	-	504000002
Adjustable 14" leg	4-1/2 thru 9-1/2"	Less than 4-1/2"	504000003
Adjustable 18" leg	9 thru 14"	4-1/2 thru 8-1/2"	504000004
Adjustable 23" leg	13-1/2 thru 18-1/2"	8-1/2 thru 13-1/2"	504000005
Adjustable 27" leg	18 thru 23"	13-1/2 thru 17-1/2"	504000006
Adjustable 32" leg	22-1/2 thru 27-1/2"	17-1/2 thru 22-1/2"	504000007

NS-30 or NS-40 Legs – 5/16" Leg Diameter

Part Description	Stud Length	Part Number
Adjustable 7" leg	Less than 4-1/2"	504000037
Adjustable 12" leg	4-1/2 thru 9-1/2"	504000038
Adjustable 17" leg	9 thru 14"	504000039
Adjustable 22" leg	14-1/2 thru 19-1/2"	504000040

Accessories

Miscellaneous Capacitor Discharge Accessories

NELSON STUD WELDING SPECIFICATION

Accessories for Welding 12 ga. **TPC** Insulation Pins

Part Description	Stud Length	Part Number
Chuck	3/4" (1/2" deep)	500001169
Chuck	Larger than 1" (3/4" deep)	500001153
Morse Taper Adapter	--	521001014
Spark Shield	Less than 3-1/2" long	511001002
Spark Shield	3-1/2" long and over	511001004

Accessories for Welding 10 ga. **TPC** Insulation Pins

Part Description	Stud Length	Part Number
Chuck	Larger than 1" (3/4" deep)	500001149
Morse Taper Adapter	--	521001014
Spark Shield*	Less than 3-1/2" long	511001002
Spark Shield*	3-1/2" long and over	511001004

* Use foot #502001002 for NS-20 gun, and #502001138 for NS-30 and NS-40 guns.

Accessories for Welding 10 ga. **P2P** Insulation Pins

Part Description	Stud Length	Part Number
Chuck	Larger than 1" (3/4" deep)	500001149
Morse Taper Adapter	--	521001014
Ferrule Grip	--	501001003

Accessories for Welding 10 ga. or 12 ga. **CHP** Insulation Pins

Part Description	Stud Length	Part Number
Chuck – Magnetic Type	10 or 12 ga.	500015093
Chuck – Grip Type	12 ga., 1-3/16" diameter	500015094
Chuck – Grip Type	10 ga., 1-1/2" diameter	500015095
Morse Taper Adapter	--	521001023
Foot – Standard; NS-20*	--	503011030
Foot – Swivel; NS-20, NS-30, and NS-40*	--	503011040
Foot – Standard; NS-30 and NS-40*	--	503011050

* Supplied with stop screws for welding pins up to 1-1/2" long. Optional stop screw, #503011033, for pins 1-1/2–4" long is available.

P2P

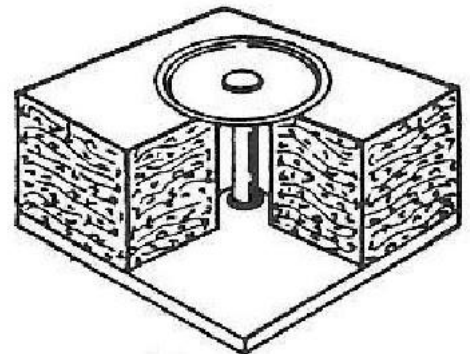
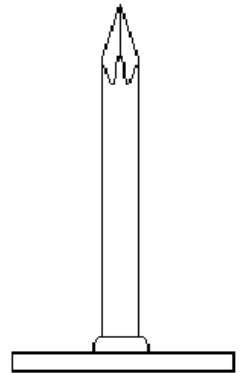

CHP (Cup-Headed Pins)

Accessories

Miscellaneous Stored Arc Accessories

NELSON STUD WELDING SPECIFICATION

Standard Length Straight-Style Chucks

Stud Diameter	Part Number
1/8" and 11 ga.	501001001
#6 threaded and 10 ga.	501001002
#8 threaded and 8 ga.	501001006
#10 threaded and 3/16"	501001005
1/4"	501001007

Gun Description	Standard Feet	Spark Shield
NSA-80A	502001137	511001108
NSA-80	502001002	511001002

Standard Gas Adapter Feet

(For welding Aluminum studs)

Stud Diameter	Part Number
Standard Gas Adapter Foot* (Includes NSA-80A Gas Spark Shield)	751022000
NSA-80A Gas Spark Shield	511002001

* Long style chuck required for studs under 3/4" long.



Nelson® Stud Welding

7900 W. Ridge Rd. • Elyria, OH 44035 USA • PH: +1 (440)-329-0400 • Fax: +1-(440) 329-0526 • www.NelsonStud.com
 USA • Canada • Mexico • Germany • China • France • Italy • UK • India